

## DVD Recorder

Operating Instructions

RDR-GX210



**SHOWVIEW®**

# WARNING

To prevent fire or shock hazard, do not expose the unit to rain or moisture. To avoid electrical shock, do not open the cabinet. Refer servicing to qualified personnel only. The mains lead must only be changed at a qualified service shop.

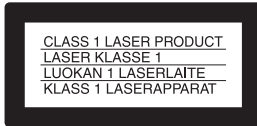

This appliance is classified as a CLASS 1 LASER product. The CLASS 1 LASER PRODUCT MARKING is located on the rear exterior.

## CAUTION

The use of optical instruments with this product will increase eye hazard. As the laser beam used in this DVD recorder is harmful to eyes, do not attempt to disassemble the cabinet. Refer servicing to qualified personnel only.



This label is located on the laser protective housing inside the enclosure.

## Notice for customers in the United Kingdom and Republic of Ireland

A moulded plug complying with BS1363 is fitted to this equipment for your safety and convenience. Should the fuse in the plug supplied need to be replaced, a 5 AMP fuse approved by ASTA or BSI to BS1362, (i.e., marked with ⚡ or ⚡ mark) must be used.

If the plug supplied with this equipment has a detachable fuse cover, be sure to attach the fuse cover after you change the fuse. Never use the plug without the fuse cover. If you should lose the fuse cover, please contact your nearest Sony service station.

## Precautions

- This unit operates on 220 – 240 V AC, 50/60 Hz. Check that the unit's operating voltage is identical with your local power supply.
- To prevent fire or shock hazard, do not place objects filled with liquids, such as vases, on the apparatus.

SHOWVIEW is a registered trademark of Gemstar Development Corporation. The SHOWVIEW system is manufactured under license from Gemstar Development Corporation.

## Disposal of Old Electrical & Electronic Equipment (Applicable in the European Union and other European countries with separate collection systems)



This symbol on the product or on its packaging indicates that this product shall not be treated as household waste. Instead it shall be handed over to the applicable collection point for the recycling of electrical and electronic equipment. By ensuring this product is disposed of correctly, you will help prevent potential negative consequences for the environment and human health, which could otherwise be caused by inappropriate waste handling of this product. The recycling of materials will help to conserve natural resources. For more detailed information about recycling of this product, please contact your local city office, your household waste disposal service or the shop where you purchased the product.

# Precautions

This equipment has been tested and found to comply with the limits set out in the EMC Directive using a connection cable shorter than 3 metres.

## On safety

Should any solid object or liquid fall into the cabinet, unplug the recorder and have it checked by qualified personnel before operating it any further.

## On power sources

- The recorder is not disconnected from the AC power source (mains) as long as it is connected to the wall outlet, even if the recorder itself has been turned off.
- If you are not going to use the recorder for a long time, be sure to disconnect the recorder from the wall outlet. To disconnect the AC power cord (mains lead), grasp the plug itself; never pull the cord.
- Do not disconnect the AC power cord (mains lead) while the recorder is in use.

## On placement

- Place the recorder in a location with adequate ventilation to prevent heat build-up in the recorder.
- Do not place the recorder on a soft surface such as a rug that might block the ventilation holes.
- Do not place the recorder in a confined space such as a bookshelf or similar unit.
- Do not place the recorder in a location near heat sources, or in a place subject to direct sunlight, excessive dust, or mechanical shock.
- Do not place the recorder in an inclined position. It is designed to be operated in a horizontal position only.
- Keep the recorder and discs away from equipment with strong magnets, such as microwave ovens, or large loudspeakers.
- Do not place heavy objects on the recorder.

## On recording

- Note that the contents of the recording cannot be compensated for under any and all conditions, including conditions that may arise due to a malfunction of this unit.
- Make trial recordings before making the actual recording.

## Copyrights

- Television programmes, films, video tapes, discs, and other materials may be copyrighted. Unauthorized recording of such material may be contrary to the provisions of the copyright laws. Also, use of this recorder with cable television transmission may require authorization from the cable television transmitter and/or programme owner.
- This product incorporates copyright protection technology that is protected by U.S. patents and other intellectual property rights. Use of this copyright protection technology must be authorized by Macrovision, and is intended for home and other limited viewing uses only unless otherwise authorized by Macrovision. Reverse engineering or disassembly is prohibited.

## Copy guard function

Since the recorder has a copy guard function, programmes received through an external tuner (not supplied) may contain copy protection signals (copy guard function) and as such may not be recordable, depending on the type of signal.

If you have any questions or problems concerning your recorder, please consult your nearest Sony dealer.

## About this manual

- Instructions in this manual describe the controls on the remote. You can also use the controls on the recorder if they have the same or similar names as those on the remote.
- The option names and messages that appear on the screen are enclosed in brackets.
- The on-screen display illustrations used in this manual may not match the graphics displayed on your TV screen.
- The explanations regarding discs in this manual refer to discs created on this recorder. The explanations do not apply to discs that are created on other recorders and played back on this recorder.

### **IMPORTANT NOTICE**

Caution: This recorder is capable of holding a still video image or on-screen display image on your television screen indefinitely. If you leave the still video image or on-screen display image displayed on your TV for an extended period of time you risk permanent damage to your television screen. Plasma display panels and projection televisions are especially susceptible to this.

# Table of Contents

WARNING	2
Precautions	2
Ways to Use Your DVD Recorder	6
Quick Guide to Disc Types	8

---

## Hookups and Settings . . . . . 12

Hooking Up the Recorder	12
Step 1: Unpacking	12
Step 2: Connecting the Aerial Cable	13
Step 3: Connecting the Video Cords	14
Step 4: Connecting the Audio Cords	16
Step 5: Connecting the Mains Lead	18
Step 6: Preparing the Remote	18
Step 7: Initial Setup	21
Connecting a VCR or Similar Device	23
Connecting to a Satellite or Digital Tuner	25
Connecting a PAY-TV/Canal Plus Decoder	26

---

## Basic Operation . . . . . 27

Inserting and Formatting a Disc	27
Recording a Programme to a Disc	28
Viewing the Recorded Programme (Title List)	29
Checking the Playback Information and Playing Time	31
Changing the Name of a Recorded Programme (Title Input)	32
Labelling and Protecting a Disc	34
Playing a DVD on Other Equipment (Finalize)	35

---

## Recording . . . . . 37

Before Recording	37
Timer Recording (Standard/ShowView)	38
Checking/Changing/Canceling Timer Settings (Timer List)	42
Recording Without the Timer	43
Recording From Connected Equipment	45

---

## Playback . . . . . 47

Playing DVDs and VIDEO CDs	47
Searching for a Title/Chapter/Track, etc.	52
Playing Music CDs and MP3 Audio Tracks	53
Playing JPEG Image Files	57

---

## Erasing and Editing . . . . . 59

Before Editing	59
Erasing and Editing Titles	60
Editing a Title by Chapter	63
Editing a Playlist	64

---

<b>DV Dubbing</b> .....	<b>66</b>
Before DV Dubbing .....	66
Connecting a Digital Video Camera to the DV IN Jack .....	66
Dubbing From a DV/Digital8 Format Tape to a DVD .....	67

---

<b>Settings and Adjustments</b> .....	<b>69</b>
Using the Setup Displays .....	69
Channel and Clock Settings .....	70
TV and Video Settings .....	73
Language Settings .....	74
Audio Settings .....	75
Parental Control Settings .....	76
Recording Settings .....	77
Resetting the Recorder (Factory Setup) .....	78

---

<b>Additional Information</b> .....	<b>79</b>
Troubleshooting .....	79
Notes About This Recorder .....	83
Specifications .....	84
About i.LINK .....	85
Guide to Parts and Controls .....	86
Glossary .....	90
Language Code List .....	92
Area Code List .....	93
Index .....	94

# Ways to Use Your DVD Recorder

## Quick access to recorded titles – Title List

- ➔ Display the Title List to see all of the titles on the disc, including recording date, title length, and thumbnail image (page 29).

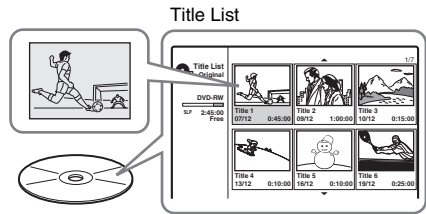

## Creating your own programme – Playlist

- ➔ Record a programme on a DVD-RW (VR mode), then delete, move and add scenes as will to create your own, original programme (page 59).

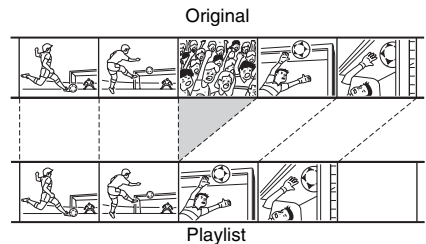

## Dubbing of DV/Digital8 tapes – DV Dubbing

- ➔ Connect your digital video camera to the DV IN jack and dub the entire contents or just selected scenes to a DVD disc (page 66).

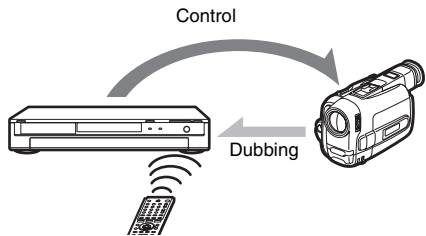

---

## Progressive PAL playback

- ➔ If your TV is compatible with progressive signals, you can enjoy accurate colour reproduction and high quality images in Progressive mode.

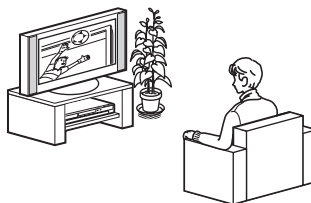

---

## Playing JPEG image files



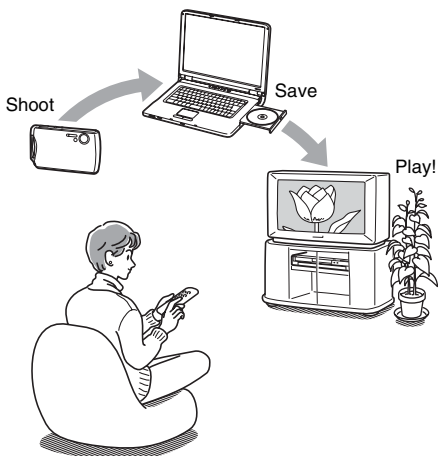





- ➔ You can enjoy viewing JPEG images on your TV screen. First, take pictures with a digital camera and save them in JPEG format to a CD-RW/CD-R on a PC. Then play the CD-RW/CD-R on this recorder (page 57).



A list of recordable and playable discs is on page 8.

# Quick Guide to Disc Types

## Recordable and playable discs

Type	Disc Logo	Icon used in this manual	Formatting (new discs)	Compatibility with other DVD players (finalizing)
DVD+RW	 DVD+ReWritable		Automatically formatted	Playable on DVD+RW compatible players (automatically finalized)
DVD-RW			Automatically formatted in VR mode	Playable only on VR mode compatible players (finalization unnecessary)
			Manually reformat in Video mode (page 27)	Playable on most DVD players (finalization necessary) (page 35)
DVD+R	 DVD+R		Automatically formatted	Playable on most DVD+R compatible players (finalization necessary) (page 35)
DVD-R	 R R4.7		Automatically formatted	Playable on most DVD players (finalization necessary) (page 35)

### Usable disc versions (as of February 2005)

- 4x-speed or slower DVD+RWs
- 4x-speed or slower DVD-RWs (Ver.1.1, Ver.1.2 with CPRM\*1)
- 8x-speed or slower DVD+Rs
- 8x-speed or slower DVD-Rs (Ver.2.0)

“DVD+RW,” “DVD-RW,” “DVD+R,” and “DVD-R,” are trademarks.

\*1 CPRM (Content Protection for Recordable Media) is a coding technology that protects copyrights for images.

\*2 To free up disc space, erase the last title on the disc.

\*3 Erasing titles does not free up disc space.











	Recording Features			Editing Features				
	Rewrite (page 37)	Record 16:9 sizes (page 77)	Auto chapter (page 77)	Erase title (page 61)	A-B Erase (page 61)	Manual chapter (page 64)	Erase chapter/ Hide chapter (page 64)	Playlist (page 59)
	Yes	No	Yes	Yes * <sup>2</sup>	No	Yes	No/Yes	No
	Yes	Yes	Yes	Yes	Yes	Yes	Yes/No	Yes
	Yes	No	Yes	Yes * <sup>2</sup>	No	No	No/No	No
	No	No	Yes	Yes * <sup>3</sup>	No	Yes	No/Yes	No
	No	No	Yes	Yes * <sup>3</sup>	No	No	No/No	No

### Discs that cannot be recorded on

- DVD-RWs (Ver. 1.0)
- DVD+RWs that are not 2.4x-speed compatible
- Double layer discs
- 8 cm discs

## Playable discs

Type	Disc Logo	Icon used in this manual	Characteristics
DVD VIDEO			Discs such as movies that can be purchased or rented
VIDEO CD			VIDEO CDs or CD-Rs/CD-RWs in VIDEO CD/Super VIDEO CD format
CD			Music CDs or CD-Rs/CD-RWs in music CD format that can be purchased
DATA CD			CD-ROMs/CD-Rs/CD-RWs containing MP3 audio tracks and JPEG image files

### Note about CDs

The recorder can play CD-ROMs/CD-Rs/CD-RWs recorded in the following formats:

- music CD format
- video CD format
- MP3 audio tracks and JPEG image files of format conforming to ISO9660\* Level 1/Level 2, or its extended format, Joliet

\* A logical format of files and folders on CD-ROMs, defined by ISO (International Organization for Standardization).

### Discs that cannot be played

- All CD-ROMs (including PHOTO CDs)
- CD-Rs/CD-RWs, other than those recorded in the format, listed above
- Data part of CD-Extras
- DVD-ROMs
- DVD Audio discs
- DVD-RAMs
- DVD+R DL (double layer) discs
- HD layer on Super Audio CDs
- DVD VIDEOS with a different region code (page 11)

### Hint

This recorder can play 8 cm CDs and finalized 8 cm DVDs.

## Note on playback operations of DVD VIDEOS/VIDEO CDs

Some playback operations of DVD VIDEOS/VIDEO CDs may be intentionally set by software producers. Since this recorder plays DVD VIDEOS/VIDEO CDs according to the disc contents the software producers designed, some playback features may not be available. Also, see the instructions supplied with the DVD VIDEOS/VIDEO CDs.

### Region code (DVD VIDEO only)

Your recorder has a region code printed on the rear of the unit and will only play DVD VIDEOS (playback only) labelled with identical region codes. This system is used to protect copyrights. DVD VIDEOS labelled  will also play on this recorder.

If you try to play any other DVD VIDEO, the message [Playback prohibited by region code] will appear on the TV screen. Depending on the DVD VIDEO, no region code indication may be labelled even though playing the DVD VIDEO is prohibited by area restrictions.



Region code

## Music discs encoded with copyright protection technologies

This product is designed to play back discs that conform to the Compact Disc (CD) standard. Recently, various music discs encoded with copyright protection technologies are being marketed by some record companies. Please be aware that among those discs, there are some that do not conform to the CD standard and may not be playable by this product.

### Note on DualDiscs

This product is designed to playback discs that conform to the Compact Disc (CD) standard. A DualDisc is a two sided disc product which mates DVD recorded material on one side with digital audio material on the other side. Please be aware that the audio side of a DualDisc may not play on this product because these discs do not conform to the CD standard.

“DualDisc” is a trademark of the Recording Industry Association of America (RIAA).

## Notes

- Some DVD+RWs/DVD+Rs, DVD-RWs/DVD-Rs, or CD-RWs/CD-Rs cannot be played on this recorder due to the recording quality or physical condition of the disc, or the characteristics of the recording device and authoring software. The disc will not play if it has not been correctly finalized. For more information, see the operating instructions for the recording device.
- You cannot mix VR mode and Video mode on the same DVD-RW. To change the disc's format, reformat the disc (page 27). Note that the disc's contents will be erased after reformatting.
- You cannot shorten the time required for recording even with high-speed discs.
- It is recommended that you use discs with “For Video” printed on their packaging.
- You cannot add new recordings to DVD-RWs (Video mode) or DVD-Rs that contain recordings made on other DVD equipment.
- In some cases, you may not be able to add new recordings to DVD+RWs that contain recordings made on other DVD equipment. If you do add a new recording, note that this recorder will rewrite the DVD menu.
- If the disc contains PC data unrecognizable by this recorder, the data may be erased.

# Hooking Up the Recorder

Follow steps 1 to 6 to hook up the recorder, and step 7 to make the initial settings for the recorder (page 21).

### Notes

- Plug cords securely to prevent unwanted noise.
- See the instructions supplied with the components to be connected.
- You cannot connect this recorder to a TV that does not have a SCART or video input jack.
- Be sure to disconnect the mains lead of each component before connecting.

## Step 1: Unpacking

Check that you have the following items:

- Audio cord (pinplug × 2 ↔ pinplug × 2) (1)
- Video cord (pinplug × 1 ↔ pinplug × 1) (1)
- Aerial cable (1)
- Remote commander (remote) (1)
- R6 (size AA) batteries (2)

## Step 2: Connecting the Aerial Cable

Connect the aerial cable by following the steps below. Do not connect the mains lead until you reach “Step 5: Connecting the Mains Lead” (page 18).

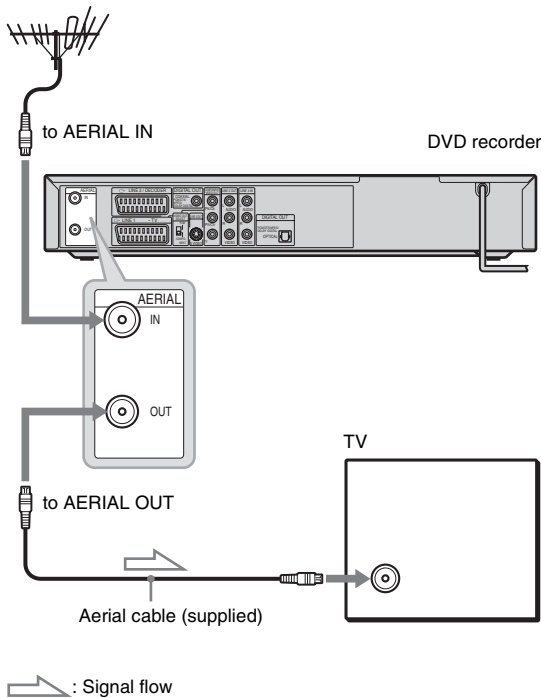

- 1** Disconnect the aerial cable from your TV and connect it to AERIAL IN on the rear panel of the recorder.
- 2** Connect AERIAL OUT of the recorder to the aerial input of your TV, using the supplied aerial cable.

## Step 3: Connecting the Video Cords

Select one of the following patterns **A** through **D**, according to the input jack on your TV monitor, projector, or AV amplifier (receiver). This will enable you to view pictures. Audio connections are explained in “Step 4: Connecting the Audio Cords” (page 16).

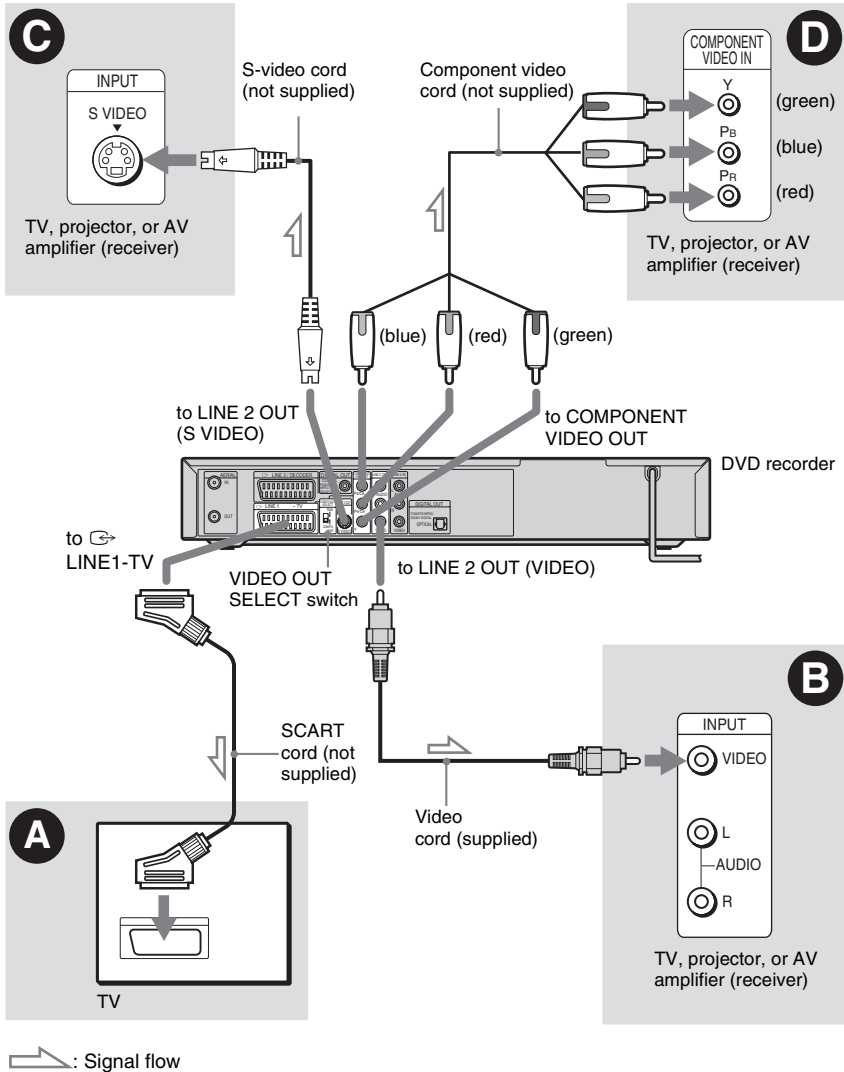

### Note

Do not connect more than one type of video cord between the recorder and your TV at the same time.

## A Connecting to a SCART input jack

Connect using a SCART cord (not supplied) to the LINE 1-TV jack and your TV. Be sure to make the connections firmly to avoid hum and noise. See the operating instructions supplied with the TV to be connected. Set the VIDEO OUT SELECT switch on the rear panel to “RGB.”



## B Connecting to a video input jack

Connect using the video cord (supplied) to the yellow LINE 2 OUT (VIDEO) jack. You will enjoy standard quality images.



## C Connecting to an S VIDEO input jack

Connect using an S-video cord (not supplied) to the LINE 2 OUT (S VIDEO) jack. You will enjoy high quality images.



## D Connecting to component video input jacks (P<sub>B</sub>/C<sub>B</sub>, P<sub>R</sub>/C<sub>R</sub>, Y)

Connect the COMPONENT VIDEO OUT jacks using a component video cord (not supplied) or three video cords (not supplied) of the same kind and length. You will enjoy accurate colour reproduction and high quality images. Set the VIDEO OUT SELECT switch on the rear panel to “COMPONENT.”

If your TV accepts progressive 625p format signals, you must use this connection and set [Progressive Mode] in [Settings] Setup to [On] (see page 73). The PROGRESSIVE indicator lights up on the recorder.



## When playing “wide screen” images

Some recorded images may not fit your TV screen. To change the aspect ratio, see page 73.

## If you are connecting to a VCR

Connect your VCR to the LINE 3/DECODER jack on the recorder (page 23).

### Notes

- Consumers should note that not all high definition television sets are fully compatible with this product and may cause artifacts to be displayed in the picture. In the case of 625 progressive scan picture problems, it is recommended that the user switch the connection to the ‘standard definition’ output. If there are questions regarding our TV set compatibility with this model 625p DVD recorder, please contact our customer service centre.
- When you connect the recorder to your TV via the SCART jacks, the TV’s input source is set to the recorder automatically when you turn the recorder on. If necessary, press TV/DVD on the remote to return the input to the TV.

# Step 4: Connecting the Audio Cords

Select one of the following patterns **A** or **B**, according to the input jack on your TV monitor, projector, or AV amplifier (receiver).

This will enable you to listen to sound.

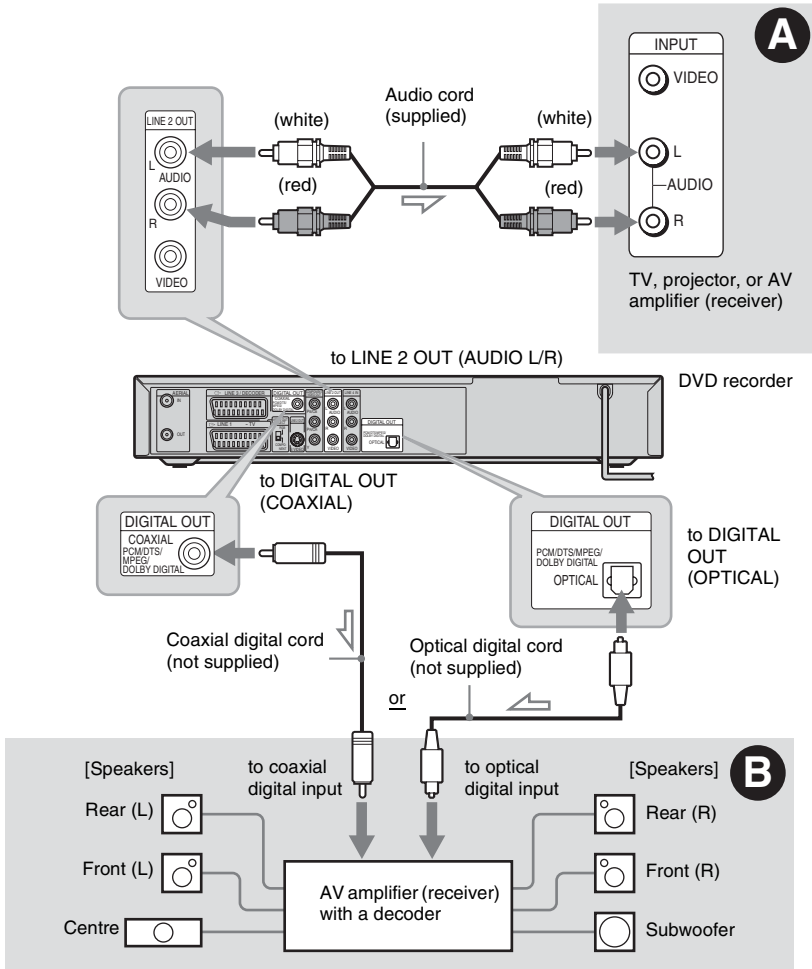

: Signal flow

### Hint

For correct speaker location, see the operating instructions supplied with the connected components.

### Note

Do not connect your TV's audio output jacks to the LINE IN (AUDIO L/R) jacks at the same time. This will cause unwanted noise to come from your TV's speakers.



## A Connecting to audio L/R input jacks

This connection will use your TV's or stereo amplifier's (receiver's) two speakers for sound. Connect using the audio cord (supplied).



- Surround effect (page 49)



### Note

Do not connect the LINE 4 IN (AUDIO L/R) and LINE 2 OUT (AUDIO L/R) jacks to your TV's audio output jacks at the same time. This will cause unwanted noise to come from your TV's speakers.

## B Connecting to a digital audio input jack

If your AV amplifier (receiver) has a Dolby\*<sup>1</sup> Digital, DTS\*<sup>2</sup>, or MPEG audio decoder and a digital input jack, use this connection.

Connect using a coaxial or optical digital cord (not supplied).

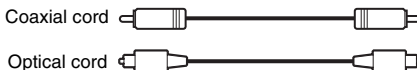

- Surround effect  
Dolby Digital (5.1ch), DTS (5.1ch), MPEG audio (5.1ch)

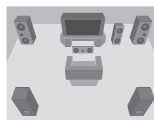

\*<sup>1</sup> Manufactured under license from Dolby Laboratories. "Dolby," "Pro Logic," and the double-D symbol are trademarks of Dolby Laboratories.

\*<sup>2</sup> "DTS" and "DTS Digital Out" are registered trademarks of Digital Theater Systems, Inc.

### Notes

- After you have completed connection **B**, make the appropriate settings under [Audio] Setup (page 75). If your AV amplifier (receiver) has an MPEG audio decoder function, set [MPEG] to [Bitstream] in [Audio] Setup (page 75). Otherwise, no sound or a loud noise will come from your speakers.
- The surround sound effects of this recorder cannot be used with connection **B**.

## Step 5: Connecting the Mains Lead

Plug the recorder and TV mains leads (power cords) into the mains. After you connect the mains lead, **you must wait for a short while before operating the recorder**. You can operate the recorder once the front panel display lights up and the recorder enters standby mode.

If you connect additional equipment to this recorder (page 23), be sure to connect the mains lead after all connections are complete.

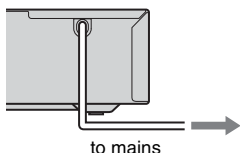

## Step 6: Preparing the Remote

You can control the recorder using the supplied remote. Insert two R6 (size AA) batteries by matching the ⊕ and ⊖ ends on the batteries to the markings inside the battery compartment. When using the remote, point it at the remote sensor  on the recorder.

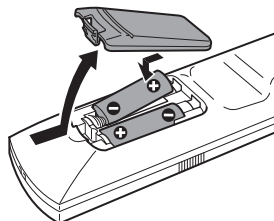

### Notes

- If the supplied remote interferes your other Sony DVD recorder or player, change the command mode number for this recorder (page 20).
- Use the batteries correctly to avoid possible leakage and corrosion. Do not touch the liquid with bare hands should leakage occur. Observe the following:
  - Do not use a new battery with an old battery, or batteries of different manufacturers.
  - Do not attempt to recharge the batteries.
  - If you do not intend to use the remote for an extended period of time, remove the batteries.
  - If battery leakage occurs, wipe out any liquid inside the battery compartment, and insert new batteries.
- Do not expose the remote sensor (marked  on the front panel) to strong light, such as direct sunlight or lighting apparatus. The recorder may not respond to the remote.

## Controlling TVs with the remote

You can adjust the remote's signal to control your TV.

If you connected the recorder to an AV amplifier (receiver), you can use the supplied remote to control the AV amplifier's (receiver's) volume.

### Notes

- Depending on the connected unit, you may not be able to control your TV or AV amplifier (receiver) with some or all of the buttons below.
- If you enter a new code number, the code number previously entered will be erased.
- When you replace the batteries of the remote, the code number may be reset to the default setting. Set the appropriate code number again.

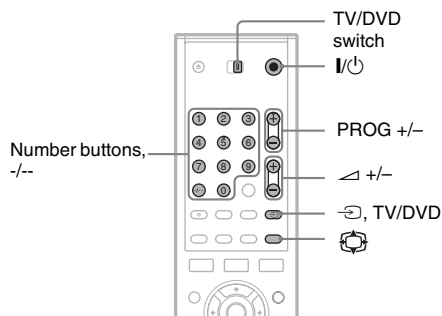

- 1 Slide the TV/DVD switch to TV.**
- 2 Hold down I/⏻.**
- 3 Enter your TV's manufacturer code (see "Code numbers of controllable TVs" below) using the number buttons.**
- 4 Release I/⏻.**

When the TV/DVD switch is set to TV, the remote performs the following:

I/⏻	Turns your TV on or off
△ (volume) +/-	Adjusts the volume of your TV
PROG +/-	Selects the programme position on your TV
⏻ (wide mode)	Switches to or from the wide mode of a Sony wide-screen TV
↺ (TV/video)	Switches your TV's input source

Number buttons and -/--*	Selects the programme position on your TV
--------------------------	---

\* If you use the number buttons to select the TV's programme position, press -/-- followed by the number buttons for two-digit numbers.

### To operate the TV/DVD button (for SCART connections only)

The TV/DVD button switches between the recorder and the last input source selected on the TV. Point your remote at the recorder when using this button. The button works even if the TV/DVD switch is set to DVD.

When you connect the recorder to the TV via the SCART jacks, the input source for the TV is set to the recorder automatically when you turn the power on. To watch another source, press the TV/DVD button to switch the TV's input source.

### Code numbers of controllable TVs

If more than one code number is listed, try entering them one at a time until you find the one that works with your TV.

Manufacturer	Code number
Sony	01 (default)
Aiwa	01 (default)
Grundig	11
Hitachi	23, 24, 72
Loewe	06, 45
Nokia	15, 16, 69, 73
Panasonic	17, 49
Philips	06, 07, 08, 23, 45, 72
Saba	12, 13, 36, 43, 74, 75
Samsung	06, 22, 23, 71, 72
Sanyo	25
Sharp	29
Telefunken	12, 13, 36, 43, 74, 75
Thomson	12, 13, 43, 74, 75
Toshiba	38
LG	06
JVC	33

## Controlling the volume of your AV amplifier (receiver) with the remote

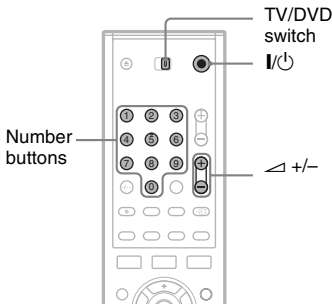

- 1** Slide the TV/DVD switch to DVD.
- 2** Hold down I/⏻, and enter the manufacturer code (see the table below) for your AV amplifier (receiver) using the number buttons.
- 3** Release I/⏻.

The  $\triangleleft$  (volume) +/- buttons control the AV amplifier's volume.  
If you want to control the TV's volume, slide the TV/DVD switch to TV.

### Hint

If you want to control the TV's volume even when the TV/DVD switch is set to DVD, repeat the steps above and enter the code number 90 (default).

### Code numbers of controllable AV amplifiers (receivers)

If more than one code number is listed, try entering them one at a time until you find the one that works with your AV amplifier (receiver).

Manufacturer	Code number
Sony	78, 79, 80, 91
Denon	84, 85, 86
Kenwood	92, 93
Onkyo	81, 82, 83
Pioneer	99
Sansui	87
Technics	97, 98
Yamaha	94, 95, 96

## If you have a Sony DVD player or more than one Sony DVD recorder

If the supplied remote interferes with your other Sony DVD recorder or player, set the command mode number for this recorder and the supplied remote to one that differs from the other Sony DVD recorder or player.

The default command mode setting for this recorder and the supplied remote is "MODE3."

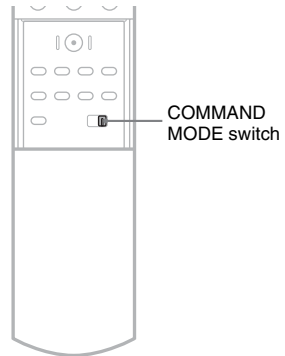
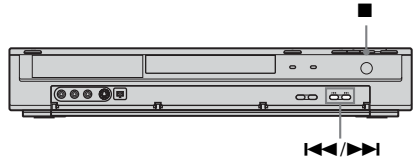

- 1** Turn off the recorder.
- 2** Press down  $\blacksquare$  (stop) on the recorder until "MODE" appears in the front panel display.
- 3** While keeping  $\blacksquare$  (stop) pressed, repeatedly press I◀▶I on the recorder to select the command mode (MODE1, 2, or 3).

Front panel display

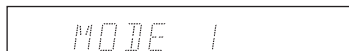

- 4** Slide the COMMAND MODE switch on the remote so it matches the mode you selected above.

## Step 7: Initial Setup

Use the Setup Displays to make the initial settings for using the recorder. Complete the initial setup in the following order.

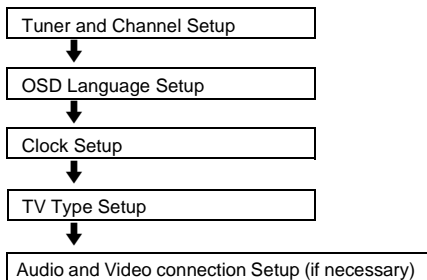

Follow the steps from “Presetting channels” to “Additional settings” below.

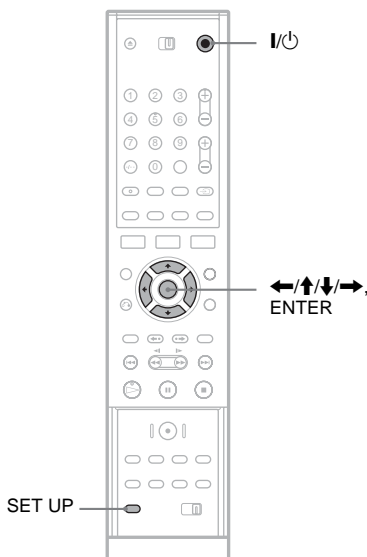

### Presetting channels

- 1 Turn on the TV.
- 2 Press I/O.
- 3 Switch the input selector on your TV so that the signal from the recorder appears on your TV screen.

### 4 Press SET UP.

The Setup Display appears, which allows you to make adjustments to the recorder. For details about the Setup Display, see page 69.

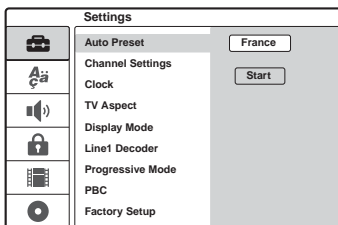

### 5 Press ↑/↓ to select your country, and press →.

If your country is not listed, select [Other]. Note that if you select [Other], you cannot select [Auto Adjust On] in [Clock] Setup (page 72).

### 6 Press ENTER while [Start] is selected.

The recorder automatically starts searching for all of the receivable channels and presets them.

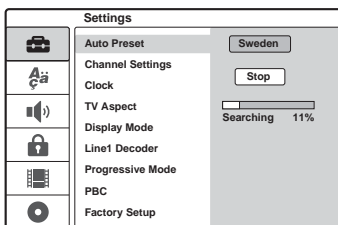

To manually set, disable, or fine-tune the channels, see “[Channel Settings]” in [Settings] Setup (page 70). For customers in France, set each channel to [SECAM] in the [Channel Settings] menu if the reception is poor (page 70).

### 7 Press ← to return to the Setup Display, and follow the steps of “Selecting a language for the on-screen display” (see below).

If you do not want to change the on-screen display language, go to “Setting the clock” (page 22).

### Selecting a language for the on-screen display

- 1 Press ↑/↓ to select [Language] (language), and press →. [Language] Setup appears.

- 2 Press **↑/↓** to select [OSD] (on-screen display), and press **→**.

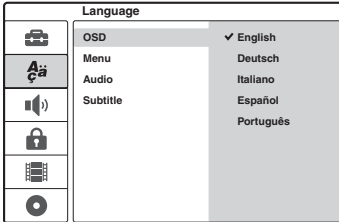

- 3 Press **↑/↓** to select a language, and press **ENTER**.

The on-screen language changes to the selected language.

- 4 Press **←** to return to the Setup Display, and follow the steps of “Setting the clock” (see below).

## Setting the clock

- 1 Press **↑/↓** to select **[Settings]**, and press **→**.  
[Settings] Setup appears.
- 2 Press **↑/↓** to select [Clock], and check that the clock is correctly set.

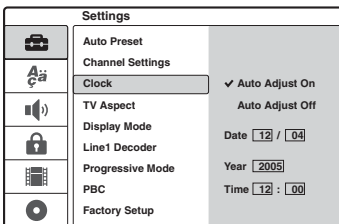

If incorrect, set the clock manually (page 72). Or, the timer recording does not work properly.

- 3 Follow the steps of “Setting the aspect ratio for the connected TV” (see below).

## Setting the aspect ratio for the connected TV

- 1 Press **↑/↓** to select [TV Aspect], and press **→**.

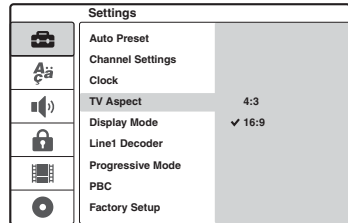

- 2 Press **↑/↓** to select the aspect ratio of the connected TV, and press **ENTER**.

[4:3]: For a standard 4:3 screen TV without a wide screen mode. Select [Display Mode] in [Settings] Setup.

[16:9]: For a wide-screen TV or standard TV with a wide screen mode.

- 3 Press **SET UP** to turn off the Setup Display. See “Additional settings” below and make other adjustments accordingly.

## Additional settings

Depending on the connected equipment, the following adjustments may be necessary.

◆ **If you connect a TV that accepts progressive 625p format signals to the COMPONENT VIDEO OUT jacks**

Set [Progressive Mode] in [Settings] Setup to [On] (page 73).

◆ **If you connect an AV amplifier (receiver) with a Dolby Digital, DTS, or MPEG audio decoder**

Make necessary settings in [Audio] Setup (page 75).

You can make other adjustments using the Setup Displays, such as picture, sound, and subtitle languages. (See “Settings and Adjustments” on page 69.)

## Connecting a VCR or Similar Device

After disconnecting the recorder's mains lead from the mains, connect a VCR or similar recording device to the LINE IN jacks of this recorder.

Use the DV IN jack on the front panel if the equipment has a DV output jack (i.LINK jack) (page 66).

See also the operating instructions supplied with the connected equipment.

To record on this recorder, see "Recording From Connected Equipment" (page 45).

### Connecting to the LINE 3 jack

Connect a VCR or similar recording device to the LINE 3/DECODER jack of this recorder.

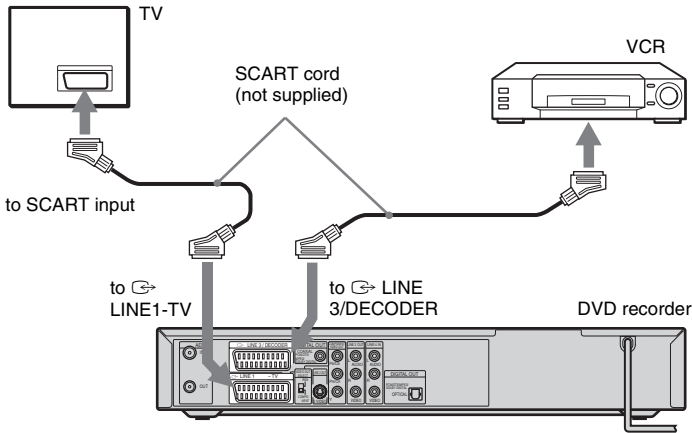

#### Notes

- Pictures containing copy protection signals that prohibit any copying cannot be recorded.
- If you pass the recorder signals via the VCR, you may not receive a clear image on your TV screen.

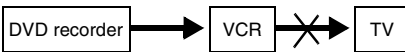

Be sure to connect your VCR to the DVD recorder and your TV in the order shown below. To watch video tapes, watch the tapes through a second line input on your TV.

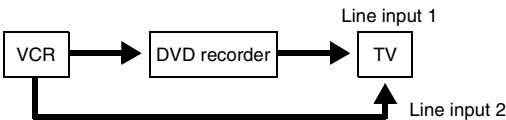

- When you record to a VCR from this DVD recorder, do not switch the input source to TV by pressing the TV/DVD button on the remote.
- If you disconnect the recorder's mains lead, you will not be able to view the signals from the connected VCR.

## Connecting to the LINE 2 IN or LINE 4 IN jacks

Connect a VCR or similar recording device to the LINE 2 IN or LINE 4 IN jacks of this recorder. If you are connecting to the LINE 2 IN jacks and the equipment has an S-video jack, you can use an S-video cord instead of a video cord.

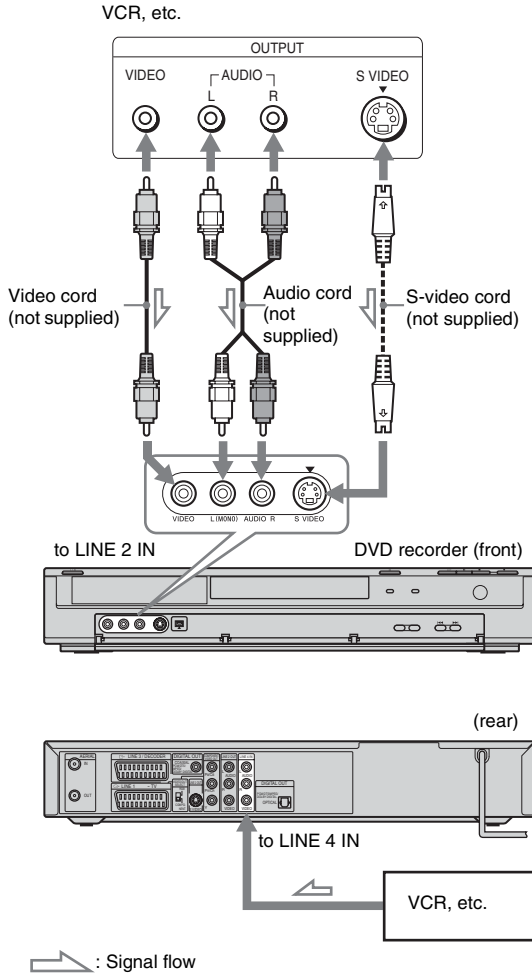

### Hint

When the connected equipment outputs only monaural sound, use audio cords that distribute monaural sounds to left/right channels (not supplied).

### Notes

- Do not connect the yellow LINE IN (VIDEO) jack when using an S-video cord.
- Do not connect the output jack of this recorder to another equipment's input jack with the other equipment's output jack connected to the input jack of this recorder. Noise (feedback) may result.
- Do not connect more than one type of video cord between the recorder and your TV at the same time.



# Connecting to a Satellite or Digital Tuner

Connect a satellite or digital tuner to this recorder using the LINE 3/DECODER jack. Disconnect the recorder's mains lead from the mains when connecting the tuner.

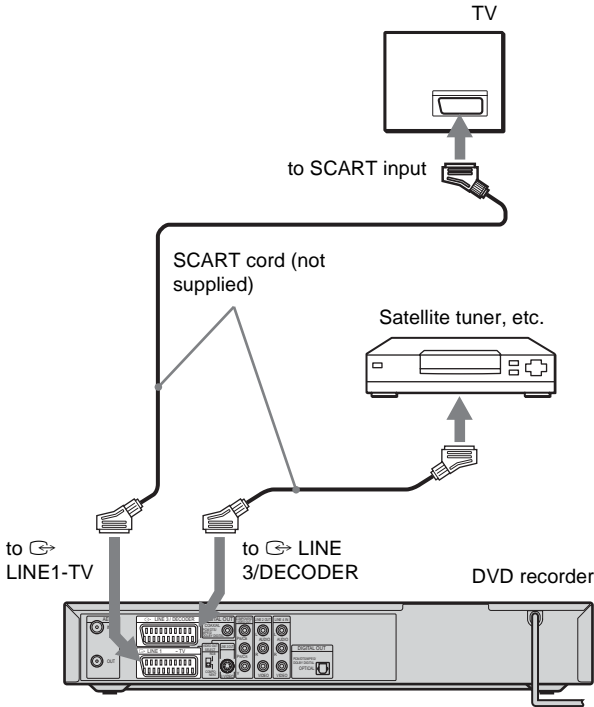

## Hint

You do not need to turn on the recorder to view the signals from the connected tuner on your TV.

## Notes

- If you are using a B Sky B tuner, be sure to connect the tuner's VCR SCART jack to the LINE 3/DECODER jack.
- If you disconnect the recorder's mains lead, you will not be able to view the signals from the connected tuner.
- When the recorder is turned off, the LINE 3/DECODER jack does not accept 16:9 screen size signals.

# Connecting a PAY-TV/Canal Plus Decoder

You can watch or record PAY-TV/Canal Plus programmes if you connect a decoder (not supplied) to the recorder. Disconnect the recorder's mains lead from the mains when connecting the decoder.

To watch or record PAY-TV/Canal Plus programmes, set your recorder to receive the channels using the Setup Display. See "[Channel Settings]" in [Settings] Setup (page 70).

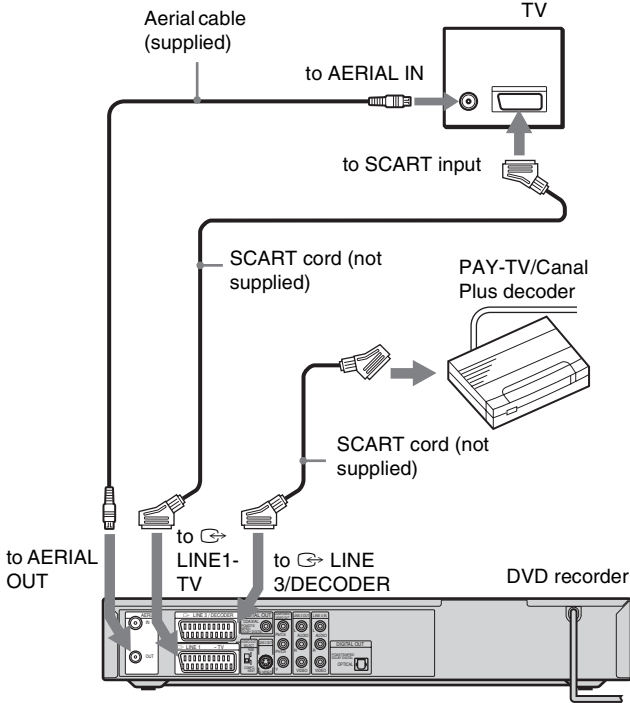

## Hint

You do not need to turn on the recorder to view the signals from the connected tuner on your TV.

## Notes

- To watch or record PAY-TV/Canal Plus programmes from the LINE 1-TV jack, set [Line1 Decoder] in [Settings] Setup to [On] (page 73).
- If you disconnect the recorder's mains lead, you will not be able to view the signals from the connected decoder.

# Inserting and Formatting a Disc

+RW -RWVR -RWVideo +R -R

When you first insert a new disc, the recorder will ask you to format the disc. Follow the steps below to format the disc. You can also reformat a DVD+RW or DVD-RW to create a blank disc.

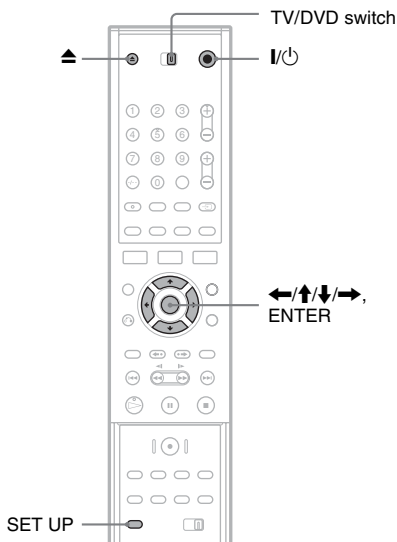

- 1 Turn on the TV.
- 2 Press I/Power.  
The recorder turns on.
- 3 Switch the input selector on your TV so that the signal from the recorder appears on the TV screen.
- 4 Slide the TV/DVD switch to DVD.
- 5 Press  $\blacktriangle$  (open/close), and place a disc on the disc tray.

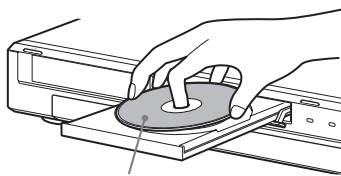

Labelled side facing up

- 6 Press  $\blacktriangle$  (open/close) to close the disc tray.

After "LOADING" disappears from the front panel display, the display asks for confirmation.

- 7 Press  $\leftarrow$  to select [OK] and press ENTER.

The recorder starts formatting the disc. The display shows the approximate time required.

- 8 Press ENTER when [OK] appears.

- For a DVD-RW, the recorder automatically formats in VR mode. To format in Video mode, see "Reformatting a disc" below.

### Hint

For a formatted disc, you can use the disc after "LOADING" disappears from the front panel display in step 6 above.

## Reformatting a disc

+RW -RWVR -RWVideo

You can erase all contents of a disc to create a blank disc. To format a new DVD-RW in Video mode, reformat the disc.

- 1 Insert a disc.
- 2 Press SET UP to turn on the Setup Display.
- 3 Select  $\bullet$  [Disc Info] and press  $\rightarrow$ .
- 4 Select [Format DVD] and press  $\rightarrow$ .

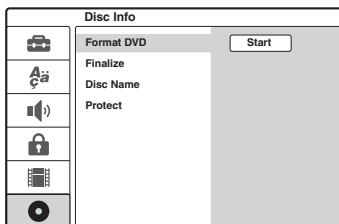

- 5 While [Start] is selected, press ENTER.

The display asks for confirmation.

- For DVD-RWs, select a recording format (VR mode or Video mode) and press ENTER.

- 6 Select [OK] and press ENTER.

Formatting starts.

# Recording a Programme to a Disc

+RW -RWVR -RWvideo +R -R

This section introduces the basic operation to record the current TV programme to a disc. For details about recording, see page 37.

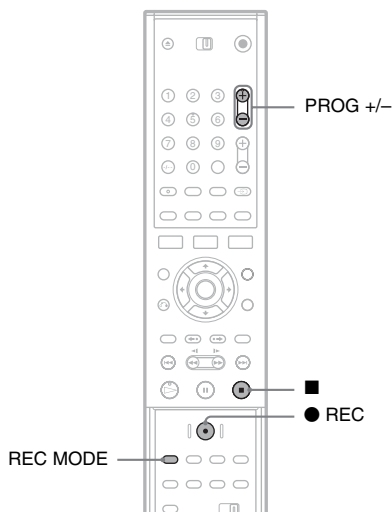

## To stop recording

Press **■**. Note that it may take a few seconds for recording to stop.

## Hint

This recorder can record on various discs. Select the disc type according to your needs (page 8).

### 1 Insert a disc.

For details on how to insert and format a new disc, see “Inserting and Formatting a Disc” (page 27).

### 2 Press PROG +/- to select the programme position you want to record.

### 3 Press REC MODE repeatedly to select the recording mode.

Each time you press the button, the display changes on the TV screen as follows:

HQ → SP → EP → SLP

For details about the recording mode, see page 37.

### 4 Press ● REC.

Recording starts and “●” (red) appears in the front panel display.

Recording continues until you stop the recording or the disc is full.

# Viewing the Recorded Programme (Title List)

**+RW** **-RWVR** **-RW<sub>Video</sub>** **+R** **-R**

The titles of programmes recorded on a disc are displayed in the Title List, which also displays disc information, such as disc name, remaining time, etc. Follow the steps below to play the recorded programme.

You can also edit individual titles from the Title List (page 60).

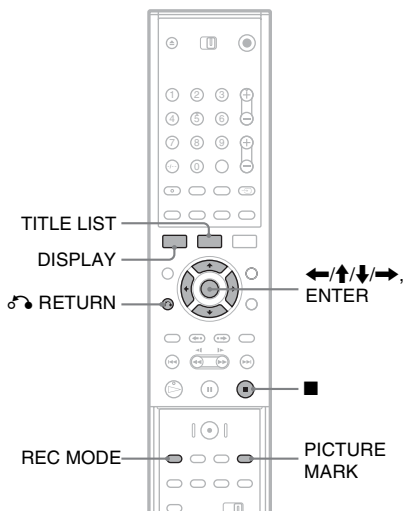

**1** Insert a disc.

**2** Press TITLE LIST.

The Title List menu appears with the contents of the disc.

Example: Title List (Original) on a DVD-RW (VR mode)

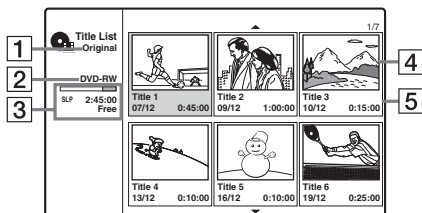

**2** Disc name (page 34):

Displays the disc type. If it is a VR mode disc, “VR” appears in the front panel display.

**3** Disc space bar/remaining time:

Press REC MODE repeatedly to show the remaining time in each of the recording modes.

**4** Title’s thumbnail picture

Press ←/→ to select the previous/next title. If more than six titles are listed, press ↑/↓ to display titles on the previous/next pages row by row.

**5** Title information:

Displays the title name, recording date, and recording time.

Press DISPLAY to show detailed information for the selected title (not available for a Playlist title).

**3** Select a title and press ENTER.

The sub-menu appears with options applicable to the selected title. The options displayed differ depending on the situation and disc type.

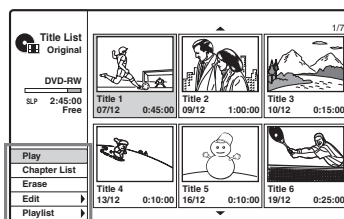

Options for the selected title

- If you want to turn off the sub-menu and re-select other title, press RETURN.

**4** Select [Play] and press ENTER.

Playback starts from the selected title on the disc.

## About the Title List for DVD-RWs (VR mode)

Each time you press TITLE LIST, you can switch the Title List to show original or Playlist.

“PLAYLIST” appears in the front panel display when “Playlist” is selected.

For details, see “Edits for Playlist titles” (page 59).

**1** Title type (DVD-RW (VR mode) only):

Displays the title type, original or Playlist.

## To change a title thumbnail picture

You can select a favourite scene for the thumbnail picture shown in the Title List menu.

- 1 Play a title whose thumbnail picture you want to change.
- 2 Press PICTURE MARK at the scene you want to set for a thumbnail picture.  
A thumbnail mark appears on the screen and the scene is set for the title's thumbnail picture.

## To stop playback

Press ■.

## To turn off the Title List

Press ⏪ RETURN.

---

## Chapter List

+RW -RWVR +R

When you select [Chapter List] from the sub-menu for a title, the Chapter List menu appears with the title contents displayed as chapters. You can play or edit individual chapters from the sub-menu, which appears when you select a chapter and press ENTER.

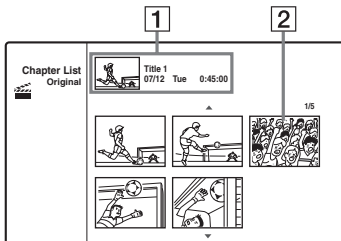

- 1 Title information
- 2 Chapter's thumbnail picture  
Press ◀/▶ to select the previous/next chapter. If more than six chapters are listed, press ▲/▼ to display chapters on the previous/next pages row by row.

---

## To return to the Title List

Select a chapter and press ENTER. Select [Title List] from the sub-menu and press ENTER.

## 💡 Hint

After recording, the first scene of the recording (the title) is automatically set as the thumbnail picture.

## Notes

- The Title List may not appear for discs created on other DVD recorders.
- Letters that cannot be displayed appear as corrupt characters.
- Title thumbnail pictures are displayed only on this recorder.
- It may take a few seconds for the thumbnail pictures to be displayed.
- After editing, the title thumbnail picture may change to the first scene of the recording (title).
- Title thumbnails are set at a point approximate to where the PICTURE MARK button is pressed, and the result may be slightly different from the intended one.

# Checking the Playback Information and Playing Time

You can check the playback information and remaining time displayed on the TV screen or the front panel display.

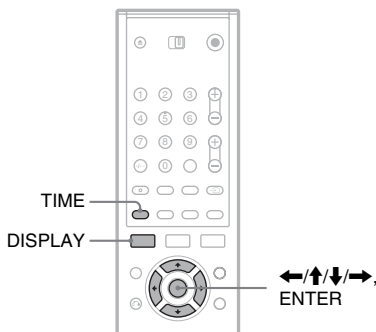

- [Time]: Elapsed playing time (52) (also displays remaining time when TIME is pressed)
- [Audio]: Selected audio language (DVD VIDEO only) or audio channel (49)
- [Subtitle]: Selected subtitle (49)
- [Angle]: Selected angle/total number of angles (49)
- [Sound]: Selected sound mode (49)

## Note

If no button is pressed for ten seconds, the playback information display will turn off.

# Checking the playing time and remaining time



You can view the playing or remaining time information displayed on the TV screen and the front panel display. The same information displayed in the front panel display is shown on the TV screen.

## Press TIME repeatedly.

The items displayed differ depending on the disc type or playing status.

# Using the on-screen display



## Press DISPLAY to show various playback information on the TV screen.

The items displayed differ depending on the disc type or playing status. To turn off the on-screen display, press DISPLAY again.

You can select an item by pressing **↑/↓** and change or select the setting by pressing **←/→**. For details about each item, see the pages in parentheses.

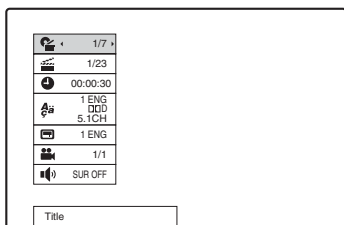

[Title]: Current title (or track) number/total number of titles (or tracks) (52)

[Chapter]: Current chapter number/total number of chapters (52)

## ◆Front panel display

Example: When playing a DVD

Playing time and number of the current title

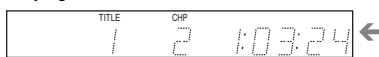

Remaining time of the current title

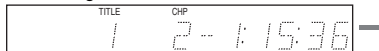

Example: When playing a CD

Track playing time and the current track number

- ↓
- Remaining time of the current track
- ↓
- Playing time of the disc
- ↓
- Remaining time of the disc

## Notes

- Playing time of MP3 audio tracks may not be displayed correctly.
- If you create a Playlist title longer than “13:15:21,” the display is reset to “0:00:00” and restarts counting.

# Changing the Name of a Recorded Programme (Title Input)

+RW -RWvR -RWvideo +R -R

The titles recorded on a disc are named sequentially ([Title 1], [Title 2], ...) by default. You can rename titles using the display for entering characters, which also appears for renaming a disc or station.

Up to 21 characters can be entered for a title or disc name and 5 characters for a station name, but the actual number of characters displayed in menus such as the Title List will vary.

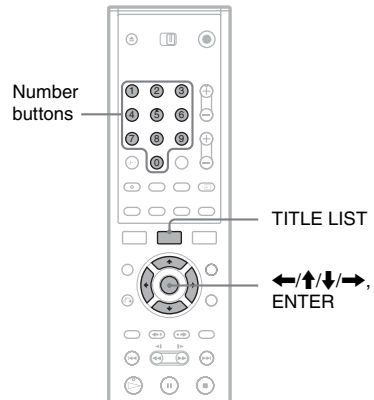

- 1 Press TITLE LIST to turn on the Title List.**  
For details about the Title List, see page 29.
- 2 Select a title and press ENTER.**
- 3 Select [Edit] from the sub-menu and press ENTER.**  
Edit options for the selected title appear.



#### 4 Select [Title Name] and press ENTER.

The display for entering characters appears.  
The default title name is displayed in the input row.

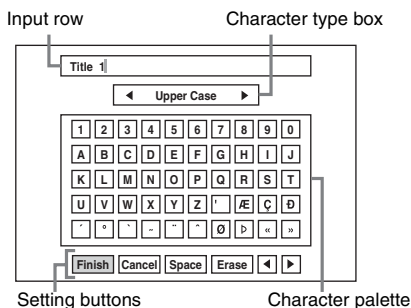

- Press  $\leftarrow/\rightarrow$  to move between the setting buttons. To move between the setting buttons, character palette, and character type box on the display, press  $\uparrow/\downarrow$ .
- To move the cursor to the left or right within the input row, select [ $\leftarrow$ ] or [ $\rightarrow$ ] and press ENTER.
- To erase a character, move the cursor to the right of the character in the input row. Select [Erase] and press ENTER.

#### 5 Move to the character type box and press $\leftarrow/\rightarrow$ to select a character type.

You can select [Upper Case], [Lower Case], or [Symbol].

The character palette switches according to the character type you select.

#### 6 Move to the character palette, press $\leftarrow/\uparrow/\downarrow/\rightarrow$ to select the character, and press ENTER.

The selected character appears in the input row.

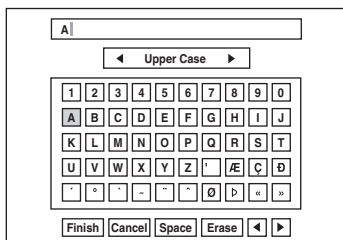

- To enter a letter with an accent mark, select the letter followed by an accent.  
Example: Select “a” and then “ ` ” to enter “à.”

- To insert a space, select [Space] and press ENTER.
- To insert a character, move the cursor to the right of the position where you want to insert the character. Select the character from the character palette and press ENTER.

#### 7 Repeat steps 5 and 6 to enter the remaining characters.

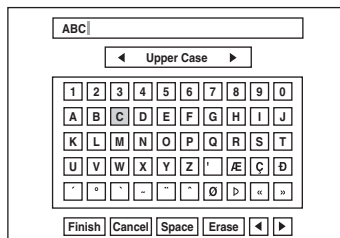

- If you want to return to the Title List without renaming the title, select [Cancel] and press ENTER.

#### 8 Select [Finish] and press ENTER.

#### To use the number buttons

You can also use the number buttons to enter characters.

- 1 Select the row containing the character to be input and press a number button.

Example: To input “MT”  
Select the “K, L, M, N, O, P, Q, R, S, T” row.  
Press the number 3 button, followed by the number 0 button.

- 2 Select [Finish] and press ENTER.

# Labelling and Protecting a Disc

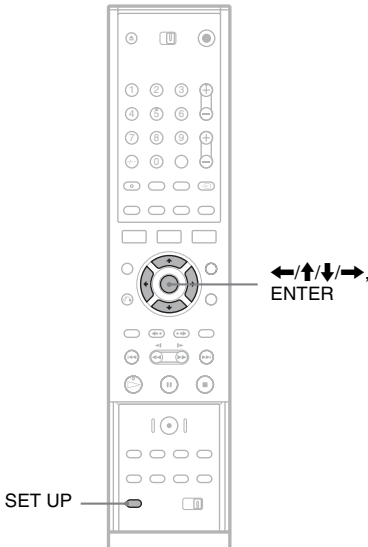

## Labelling a disc

+RW -RWVR -RWVideo +R -R

A disc is automatically labelled as its disc type. You can change the disc name (up to 21 characters).

- 1 Insert a disc.
- 2 Press SET UP to turn on the Setup Display.
- 3 Select [Disc Info] and press →.
- 4 Select [Disc Name] and press →.



- 5 While [Edit] is selected, press ENTER. The display for entering characters appears. To enter characters, see page 32.

## Note

Label the disc before you finalize it. Once a disc is finalized, you cannot change the disc name.

## Protecting a Disc

+RW -RWVR +R

You can protect all titles on the disc to prevent accidental recording, editing, or erasing.

- 1 Insert a disc.
- 2 Press SET UP to turn on the Setup Display.
- 3 Select [Disc Info] and press →.
- 4 Select [Protect] and press →.

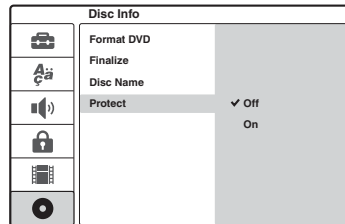

- 5 Select [On] and press ENTER.

## To cancel the protection

Repeat the steps above, and select [Off] and press ENTER in step 5.

## Hint

For DVD+RWs and DVD+Rs, you can set protection for individual titles (page 62).

## Playing a DVD on Other Equipment (Finalize)

**+RW** **-RWVR** **-RW<sub>Video</sub>** **+R** **-R**

Finalizing is necessary when you play discs recorded with this recorder on other DVD equipment.

When you finalize a DVD+RW, DVD-RW (Video mode), DVD+R, or DVD-R, a DVD menu will be automatically created, which can be displayed on other DVD equipment.

Before finalizing, check the differences between the disc types in the table below.

### Differences between the disc types

**+RW** Discs are automatically finalized when removed from the recorder. However, you may need to finalize the disc for certain DVD equipment, or if the recording time is short. You can edit or record on the disc even after finalizing.

**-RWVR** Finalizing is unnecessary when playing a disc on VR format compatible equipment. Even if your other DVD equipment is VR format compatible, you may need to finalize the disc, especially if the recording time is short. After finalizing, you cannot edit or record on it again, unfinalize the disc.

**-RW<sub>Video</sub>** Finalizing is necessary when playing on any equipment other than this recorder. After finalizing, you cannot edit or record on it again, unfinalize the disc.

**+R** Finalizing is necessary when playing on any equipment other than this recorder.

**-R** Finalizing is necessary when playing on any equipment other than this recorder. After finalizing, you cannot edit or record on the disc.

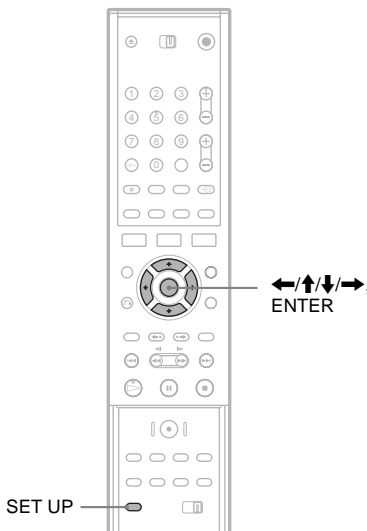

- 1 Insert a disc.
- 2 Press SET UP to turn on the Setup Display.
- 3 Select **●** [Disc Info] and press **→**.
- 4 Select [Finalize] and press **→**.



- 5 Select [Finalize] and press ENTER. The display asks for confirmation.
- 6 Select [OK] and press ENTER. The recorder starts finalizing the disc. Approximate remaining time for finalizing appears on the screen. Some discs may require more time than is indicated.
- 7 Press ENTER when [OK] appears.

### To unfinalize a DVD-RW

If you cannot record or edit on a DVD-RW that has been finalized (a message appears), unfinalize the disc by selecting [Unfinalize] in step 5 above.

### **Hint**

You can check whether the disc has been finalized or not. If you cannot select [Finalize] in step 5 above, the disc has already been finalized.

### **Notes**

- The time required for finalizing depends on the disc type, recording time, or the number of titles recorded on the disc.
- Depending on the condition of the disc, recording, or the DVD equipment, discs may not play even if the discs are finalized.
- The recorder may not be able to finalize the disc if it was recorded on another recorder.
- If the recording time is short, the disc may not be playable on some DVD players.

## Recording

# Before Recording

## Before you start recording...

- This recorder can record on various discs. Select the disc type according to your needs (page 8).
- Use the Title List to check the available recording time for the disc (page 29). For DVD+RWs and DVD-RWs, you can erase titles to free up disc space (page 59).

### Hints

- Up to 49 titles can be recorded on a DVD+RW or DVD+R. For other recordable discs, 99 titles.
- When using a DVD+RW, you can overwrite a previously recorded title (page 45).
- You can select the picture size to be recorded on DVD-RWs (VR mode). Select [4:3] or [16:9] for [Rec Aspect Ratio] in [Rec Setting] Setup (page 77).

## Recording mode

Like the SP or LP recording mode of VCRs, this recorder has four different recording modes. Select a recording mode according to the time and picture quality you need. For example, if picture quality is your top priority, select the High Quality mode (HQ). If recording time is your priority, Super Long Play mode (SLP) can be a possible choice.

### Press REC MODE repeatedly to switch the recording modes.

Note that the recording time in the following table is an approximate guide.

Recording mode	Recording time (minute)
HQ (High quality)	60
SP (Standard mode)	↑ 120
EP	↓ 240
SLP (Long duration)	360

## Notes

- Situations below may cause slight inaccuracies with the recording time.
  - Recording a programme with poor reception, or a programme or video source of low picture quality.
  - Recording on a disc that has already been edited.
  - Recording only a still picture or just sound.
- The available remaining recording time displayed is an estimate and the actual time may differ.

## Recording stereo and bilingual programmes

This recorder can receive and record stereo and bilingual programmes based on the ZWEITON system or the NICAM system.

Before you start recording bilingual programmes, press the  (audio) button repeatedly to select the audio channel (Main+Sub, Main, or Sub). The selected channel is displayed on the TV screen and applied to the recording. For timer recordings, “Main+Sub” is automatically selected. Note that you cannot switch the audio channel while recording.

### ZWEITON (German stereo) system

When a stereo or bilingual ZWEITON based programme is received, “ST” or “BIL” appears in the front panel display.

### NICAM system

When a stereo or bilingual NICAM based programme is received, “NICAM” appears in the front panel display.

To record a NICAM programme, be sure to set [NICAM/Standard] of [Channel Settings] in [Settings] Setup to on (default). If the sound is not clear when listening to NICAM broadcasts, set [NICAM/Standard] to off (see “[Channel Settings]” on page 70).

### Hint

When playing on other DVD equipment, you may not be able to switch between the main and sub sounds for bilingual programmes. Select either “Main” or “Sub” before you start recording if you plan to play the disc on other DVD equipment.

## Unrecordable pictures

Pictures with copy protection cannot be recorded on this recorder.

When the recorder receives a copy guard signal, the recorder stops recording.

Copy control signals	Recordable discs
Copy-Free	+RW   -RWVR   -RW <sub>video</sub> +R   -R
Copy-Once	-RWVR Ver.1.1, Ver.1.2 with CPRM*
Copy-Never	None

\* The recorded disc can be played only on CPRM compatible equipment.

## Timer Recording (Standard/ShowView)

+RW   -RWVR   -RW<sub>video</sub>   +R   -R

You can set the timer for a total of seven programmes, up to one month in advance. There are two methods to set the timer: the standard method and ShowView method.

- Standard: Set the date, time, and programme position of the programme manually.
- ShowView: Enter the ShowView number designated for each TV programme (page 40).

### Notes

- Timer recordings cannot be made if the recorder is turned on.
- While recording, you cannot set additional timer recordings.

## Setting the timer manually (Standard)

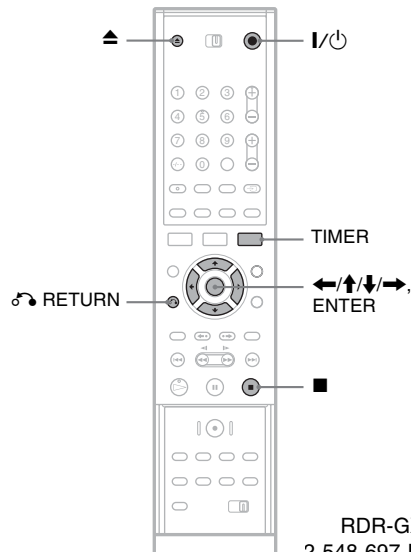

RDR-GX210  
2-548-697-E2(1)

- 1 Press **▲** (open/close), and place a recordable disc on the disc tray.

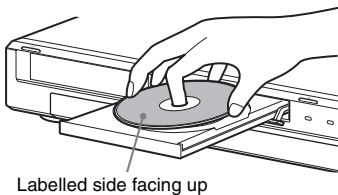

- 2 Press **▲** (open/close) to close the disc tray.

Wait until “LOADING” disappears from the front panel display.

For details on how to insert and format a new disc, see “Inserting and Formatting a Disc” (page 27).

- 3 Press **TIMER**.

Timer Standard							100 Min Free
PR	Date	Start	Stop	Mode	Repeat	PDC/VPS	
12	12/4 Tue	19:20	19:50	SP	Today	Off	

- If the Timer List or [ShowView] menu appears, press **TIMER** repeatedly to switch the display to [Timer Standard].

- 4 Press **←/→** to select an item and press **↑/↓** to adjust the setting.

[PR]: Selects the programme position or input source.

[Date]: Sets the date up to one month in advance.

[Start]: Sets the start time.

[Stop]: Sets the stop time.

[Mode]: Selects the recording mode (page 37). If you select [AT], you can use the Rec Mode Adjust function. See “Rec Mode Adjust” on page 40.

[Repeat]: Selects a repeat option from [Today], [Mon-Fri], and [Weekly].

[PDC/VPS]: Sets the PDC/VPS function. See “About the PDC/VPS function” below.

- If you make a mistake, select the item and change the setting.

- 5 Press **ENTER**.

The Timer List appears with the timer setting you made.

Timer List						+ : PDC/VPS
PR	Date	Start	Length	Mode	Check	
12	12/4 Tue	19:20	30	SP	Rec. OK	

To make another timer setting, press **TIMER** to return to the [Timer Standard] menu and repeat steps 4 and 5.

- 6 Press **↶** **RETURN** to turn off the Timer List.

- 7 Press **I/⏻** to set your recorder to standby mode.

The **TIMER REC** indicator lights up on the front panel and the recorder is ready to start recording.

### To stop recording during timer recording

Press **■**. Note that it may take a few seconds for the recorder to stop recording.

### About the PDC/VPS function

PDC/VPS signals are transmitted with TV programmes in some broadcast systems. These signals ensure that timer recordings are made regardless of any broadcast delays, early starts, or broadcast interruptions.

### ◆To use the PDC/VPS function

Set [PDC/VPS] to [On] in step 4 above. [\*] appears next to the [Start] time of the timer setting in the Timer List.

When you turn on this function, the recorder starts scanning the channel before the timer recording starts. If you are watching TV when scanning starts, a message will appear on the TV screen. If you want to watch TV, switch to your TV’s tuner.

## Rec Mode Adjust

If there is not enough available disc space for the recording, the recorder automatically selects the recording mode that will record the entire programme. To use this function, select [AT] for the recording mode and set [PDC/VPS] to [Off].

## If the timer settings overlap

If the timer settings overlap, [Dup. Date] will appear in the Timer List. For details, see “When the timer settings overlap” (page 42).

## To confirm, change, or cancel timer recording

See “Checking/Changing/Canceling Timer Settings (Timer List)” (page 42).

## Hints

- You can play the recorded programme by selecting the programme title in the Title List menu.
- You can use the recorder after setting the timer. Just press I/⏻ to turn on the recorder. Press I/⏻ again to set the recorder to standby mode before the timer recording starts.

## Notes

- Check that the clock is correctly set before setting the timer recording. If not, the timer recording cannot be made.

To record a satellite programme, turn on the satellite tuner and select the satellite programme you want to record. Leave the satellite tuner turned on until the recorder finishes recording.

- The recorder must be in standby mode for the timer recording to be made.
- Even if the timer is set for the same daily or weekly programme, the timer recording cannot be made if it overlaps with a programme that has priority. [Dup. Date] will appear for the overlapped setting in the Timer List. Check the priority order of the settings (page 42).
- Even if the timer is set, timer recordings cannot be made while recording a programme that has priority.
- The Rec Mode Adjust function only works with a timer recording and the PDC/VPS function set to off. It does not function with Quick Timer (page 44).
- The beginning of some recordings may not be made when using the PDC/VPS function.
- If the TIMER REC indicator flashes on the front panel, check that a recordable disc is inserted correctly and available recording time on the disc is enough.

## Recording TV programmes using the ShowView system

The ShowView system is a feature that simplifies setting the timer. Just enter the ShowView number listed in the TV programme guide. The date, time, and channel of that programme are set automatically.

Check that the channels are correctly set in [Channel Settings] in [Settings] Setup (page 70).

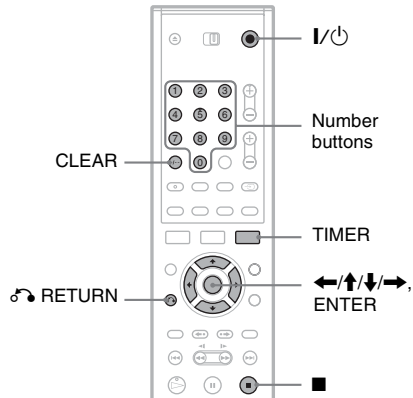

**1** Insert a recordable disc.

**2** Press **TIMER** twice.

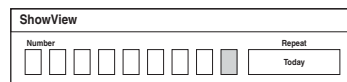

- If the Timer List or [Timer Standard] menu appears, press **TIMER** repeatedly to switch the display to [ShowView].

**3** Press the number buttons to enter the **ShowView** number.

- If you make a mistake, press **CLEAR** and re-enter the correct number.

RDR-GX210  
2-548-697-E2(1)



#### 4 Press **→** to move to [Repeat], and press **↑/↓** to select a repeat option.

You can select [Today], [Mon-Fri], or [Weekly].

#### 5 Press **ENTER**.

The programme position, date, start and stop times, recording mode, repeat option, and PDC/VPS setting (page 39) appear.

Timer Standard							100 Min Free
PR	Date	Start	Stop	Mode	Repeat	PDC/VPS	
12	12/4 Tue	19:20	19:50	SP	Today	Off	

Press **←/→** to select an item and press **↑/↓** to change the setting, if necessary.

#### 6 Press **ENTER**.

The Timer List appears with the timer setting you made.

Timer List							* : PDC/VPS
PR	Date	Start	Length	Mode	Check		
12	12/4 Tue	19:20	30	SP	Rec. OK		

To make another timer setting, press **TIMER** to return to the [ShowView] menu and repeat from step 3 to 6.

#### 7 Press **↶** **RETURN** to turn off the Timer List.

#### 8 Press **I/⏻** to set your recorder to standby mode.

The **TIMER REC** indicator lights up on the front panel and the recorder is ready to start recording.

#### To stop recording during timer recording

Press **■**. Note that it may take a few seconds for the recorder to stop recording.

#### If the timer settings overlap

If the timer settings overlap, [Dup. Date] will appear in the Timer List. For details, see “When the timer settings overlap” (page 42).

#### To confirm, change, or cancel timer recording

See “Checking/Changing/Canceling Timer Settings (Timer List)” (page 42).

#### 💡 Hints

- The Rec Mode Adjust function also works with this timer method (page 40).
- You can use the recorder after setting the timer. Just press **I/⏻** to turn on the recorder. Press **I/⏻** again to set the recorder to standby mode before the timer recording starts.

#### Notes

- Check that the clock is correctly set before setting the timer recording. If not, the timer recording cannot be made.
- The recorder must be in standby mode for the timer recording to be made.
- Even if the timer is set for the same daily or weekly programme, the timer recording cannot be made if it overlaps with a programme that has priority. [Dup. Date] will appear for the overlapped setting in the Timer List. Check the priority order of the settings (page 42).
- Even if the timer is set, timer recordings cannot be made while recording a programme that has priority.
- The beginning of some recordings may not be made when using the PDC/VPS function.
- If the **TIMER REC** indicator flashes on the front panel, check that a recordable disc is inserted correctly and available recording time on the disc is enough.

# Checking/Changing/ Cancelling Timer Settings (Timer List)

+RW -RWVR -RW<sub>video</sub> +R -R

You can check, change, or cancel timer settings using the Timer List menu.

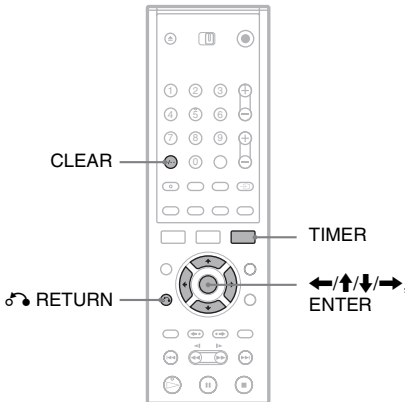

## Changing the timer settings

The Timer List can contain up to seven timer settings. You can select a timer setting and modify it before the recording starts.

### 1 Press **TIMER** repeatedly to turn on the Timer List.

All the timer settings are listed. You can check information such as the recording date, time, recording mode, etc.

Timer List						* : PDC/VPS
PR	Date	Start	Length	Mode	Check	
12	12/4 Tue	19:20	30	SP	Rec. OK	
12	13/4 Wed	20:00	30	SP	Dup. Date	
10	13/4 Wed	20:15	15	SP	Dup. Date	

- [Rec. OK] indicates that the timer recording will be made as you set. If the timer settings overlap, [Dup. Date] will appear.
- [\*] next to the [Start] time indicates that [PDC/VPS] is set to [On] (page 39).

### 2 Select a timer setting and press **ENTER**.

The programme position, date, start and stop times, recording mode, repeat option, and PDC/VPS setting for the selected timer setting appear.

### 3 Press **←/→** to select an item and press **↑/↓** to change the setting.

- If you want to return to the Timer List without changing, press **TIMER**.

### 4 Press **ENTER**.

The information for the selected timer setting is updated.

## Cancelling the timer settings

### 1 After step 1 above, select a timer setting and press **CLEAR**.

The display asks for confirmation.

### 2 Select **[OK]** and press **ENTER**.

The selected timer setting is deleted from the Timer List.

- If you want to cancel the deletion, select [Cancel] and press **ENTER** in step 2.

## To turn off the Timer List

Press **RETURN**.

## When the timer settings overlap

If a timer setting overlaps with another timer setting (i.e., [Dup. Date] appears in the Timer List), the programme that starts first has priority and the second programme starts recording only after the first programme has finished.

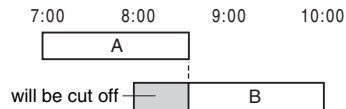

## ◆ When the recordings start at the same time

The programme that is set first has priority. In this example, timer setting A is set after B, so the first part of timer setting A will not be recorded.

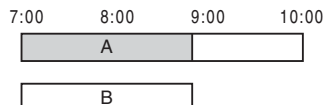

◆ **When the end time of one recording and the start time of another are the same**

After finishing the previous recording, the other recording may be delayed.

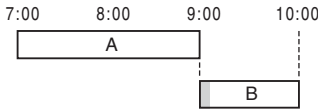

**Notes**

- While recording, you cannot change the timer setting for the current recording.
- When [PDC/VPS] is set to [On] for one or more timer recordings, the start times may change in the event of a broadcast delay or early start.
- Even if the timer is set, timer recordings cannot be made while recording a programme that has priority.
- Even if the timer is set for the same daily or weekly programme, the timer recording cannot be made if it overlaps with a programme that has priority. [Dup. Date] will appear for the overlapped setting in the Timer List. Check the priority order of the settings.

# Recording Without the Timer

+RW -RWVR -RWVideo +R -R

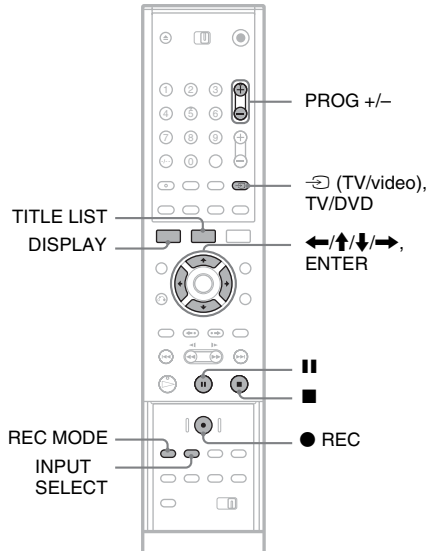

Recording

- 1 Insert a recordable disc.**
- 2 Press PROG +/- or INPUT SELECT to select the programme position or input source you want to record.**
- 3 Press REC MODE repeatedly to select the recording mode.**

Each time you press the button, the display changes on the TV screen as follows:

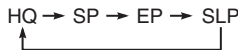

For details about the recording mode, see page 37.

- 4 Press ● REC.**  
Recording starts and "●" (red) appears in the front panel display.  
Recording continues until you stop the recording or the disc is full.

## To stop recording

Press **■**. Note that it may take a few seconds for recording to stop.

## To pause recording

Press **⏏**. To restart recording, press the button again.

## To watch another TV programme while recording

If your TV is connected to the LINE 1-TV jack, set your TV to the TV input using the TV/DVD button and select the programme you want to watch. If your TV is connected to the LINE 2 OUT or COMPONENT VIDEO OUT jacks, set the TV to TV input using the **TV/video** button (page 19).

### Hint

If you do not want to watch TV while recording, you can turn off the TV. When using a decoder, make sure to leave it on.

## Notes

- After pressing **●** REC, it may take a short while to start recording.
- You cannot change the recording mode while recording or during recording pause.
- If there is a power failure, the programme you are recording may be erased.
- You cannot watch a PAY-TV/Canal Plus programme while recording another PAY-TV/Canal Plus programme.

## Using the Quick Timer function

You can set the recorder to record in 10-minute increments.

### Press **●** REC repeatedly to set the duration.

Recording starts after the first press. The Quick Timer starts from the second press, and then each additional press increases the recording time by 10 minutes within the available free space on the disc.

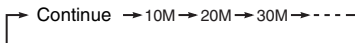

The remaining recording time appears momentarily on the TV screen.

The time counter in the front panel display decreases to 0:00 (or when the disc is full), then the recorder stops recording (power turns off).

## To check the Quick Timer

Press **●** REC once while recording. The remaining recording time and other recording information (programme position, recording mode, etc.) appear momentarily on the TV screen.

## To cancel or stop the Quick Timer

To return the recorder to normal recording mode, press **●** REC twice while recording. [Continue] appears momentarily on the TV screen.

To stop recording, press **■**. Note that it may take a few seconds for recording to stop.

## To extend the Quick Timer

Press **●** REC repeatedly while recording. After the recorder returns to normal recording mode, the recording time extends by 10 minutes (up to the capacity of the disc).

## Checking status while recording

You can check recording information such as recording time or recording mode, etc.

### Press DISPLAY during recording.

Recording information appears on the TV screen.

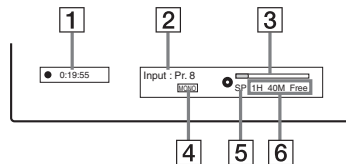

- 1 Elapsed recording time
- 2 Programme position or input source
- 3 Recording status bar
- 4 Audio channel
- 5 Recording mode
- 6 Available recording time for the disc

RDR-GX210  
12-548-697-E2(1)  
Press DISPLAY to turn off the display.

### Hint

While recording, you can check the recording time and other information, such as disc type/format, title/chapter number, etc., shown in the front panel display (page 88).

## Creating chapters in a title

The recorder automatically divides a recording (a title) into chapters by inserting chapter marks at 5-, 10-, or 15-minute intervals during recording. Select the interval, [5Min], [10Min], or [15Min] for [Auto Chapter] in [Rec Setting] Setup (page 77).

### Hint

You can create chapters manually when playing a DVD+RW, DVD-RW (VR mode), or DVD+R (page 64).

## Overwriting a recorded title

+RW

You can use the Title List to make a new recording over a title previously recorded on the disc. For details about the Title List, see page 29.

- 1 Insert a DVD+RW.
- 2 Press **PROG +/-** or **INPUT SELECT** to select a programme position or input source.
- 3 Press **TITLE LIST** to turn on the Title List.
- 4 Press **←/↑/↓/→** to select the title you want to overwrite.
- 5 Press **● REC**.  
Recording starts.

### To stop recording

Press **■**. Note that it may take a few seconds for recording to stop.

### Hint

If you erase a title from a DVD+RW, it appears as [Erased title] in the Title List. However, this will not increase the remaining time on the disc. You can select [Erased title] from the Title List and make a new recording on top of it (page 61).

### Notes

- A protected title cannot be overwritten (page 62).
- If the selected title is shorter than the new recording, or less than ten seconds, the recorder automatically overwrites the next title in the Title List. If you do not want a title to be overwritten, protect the title (page 62).

## Recording From Connected Equipment

+RW -RWVR -RWVideo +R -R

You can record from a connected VCR or similar device. To connect a VCR or similar device, see “Connecting a VCR or Similar Device” (page 23). Use the DV IN jack on the front panel if the equipment has a DV output jack (i.LINK jack).

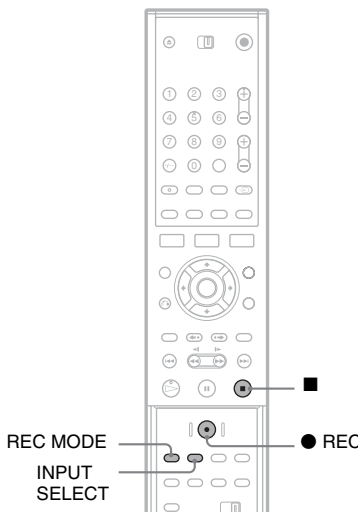

- 1 Insert a recordable disc.
- 2 Press **INPUT SELECT** to select an input source according to the connection you made.

The front panel display changes as follows:

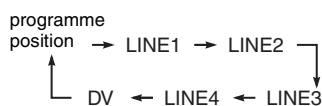

- 3 Press **REC MODE** repeatedly to select the recording mode.

The recording mode changes as follows:

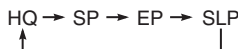

- 4 Insert the source tape into the connected equipment and set to playback pause.

**5 Press ● REC on this recorder and the pause or play button on the connected equipment at the same time.**

Recording starts.

To stop recording, press ■ on this recorder.

---

**If you connect a digital video camera with a DV IN jack**

See “DV Dubbing” (page 66) for an explanation of how to record from the DV IN jack.

**Notes**

- When recording a video game image, the screen may not be clear.
- Any programme that contains a Copy-Never copy guard signal cannot be recorded. The recorder automatically stops recording after a few seconds.

RDR-GX210  
2-548-697-E2(1)

## Playing DVDs and VIDEO CDs

+RW -RWVR -RW<sub>Video</sub> +R -R DVD  
VCD

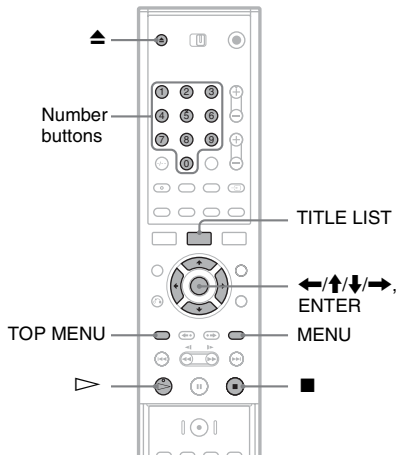

**1** Press **▲** (open/close), and place a disc on the disc tray.

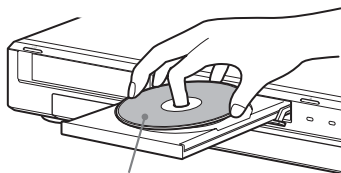

Playback side facing down

**2** Press **▲** (open/close) to close the disc tray.

If you inserted a DVD VIDEO or VIDEO CD, press **▷**. Playback starts automatically depending on the disc.

**3** Press **TITLE LIST**.

For details about the Title List, see “Viewing the Recorded Programme (Title List)” (page 29).

Example: DVD-RW (VR mode)

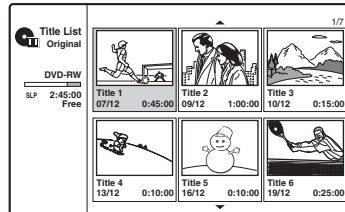

**4** Select a title, and press **ENTER**.

The sub-menu appears.

**5** Select [Play], and press **ENTER**.

Playback starts from the selected title on the disc.

**To select a chapter from the Chapter List (DVD+RW, DVD-RW (VR mode), and DVD+R only)**

**1** Select [Chapter List] from the sub-menu in step 5 above.  
The Chapter List of the selected title appears. For details about the Chapter List, see page 30.

**2** Select the chapter and press **ENTER**.

**3** Select [Play] from the sub-menu, and press **ENTER**.

Playback starts from the selected chapter.

**To use the DVD's Menu**

When you play a DVD VIDEO, or a finalized DVD+RW, DVD-RW (Video mode), DVD+R, or DVD-R, you can display the disc's menu by pressing **TOP MENU** or **MENU**.

**To play VIDEO CDs with PBC functions**

PBC (Playback Control) allows you to play VIDEO CDs interactively using the menu on your TV screen.

When you start playing a VIDEO CD with PBC functions, the menu appears.

Select an item using the number buttons and press **ENTER**. Then, follow the instructions in the menu (press **▷** when “Press SELECT” appears).

## To stop playback

Press ■.

## To resume playback from the point where you stopped the disc (Resume Play)

The recorder stores the point where you stopped the disc even if the disc is removed or the recorder turns off.

Press ■ once to stop playback. When you play the disc next time, the recorder resumes playback from the point where you stopped the disc.

To start from the beginning, press ■ twice. Playback starts from the beginning of the title/track/scene.

The point where you stopped playing is cleared when:

- you play another title.
- you edit the title after stopping playback.
- you change the settings on the recorder.
- you make a recording.

## To play restricted DVDs (Parental Control)

If you play a restricted DVD, the message [Playback limited by Parental Control.] and the display for entering your password appear on the TV screen.

- 1 Enter your four-digit password using the number buttons.
- 2 Press ENTER to select [OK].  
The recorder starts playback.

To register or change the password, see “Parental Control Settings” (page 76).

### Hints







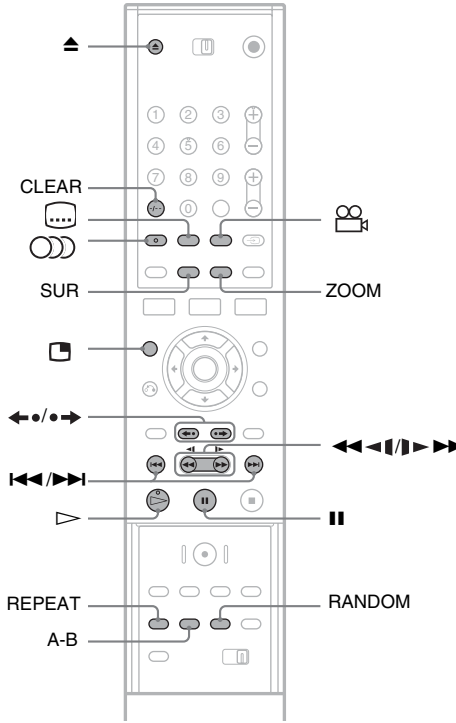

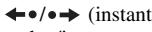

- To play without PBC functions, set [PBC] to [Off] in [Settings] Setup (page 74). VIDEO CDs are played in continuous play mode only.
- You can also use the ▷ button in step 4 (page 47) to start playback.
- To play a title including hidden chapters on a DVD+RW or DVD+R, select [Full Play] in step 5 (page 47). For details about hidden chapters, see page 64.

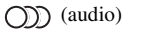

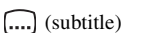
# Playback options

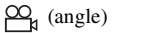

Buttons	Operations	Discs
▲ (open/close)	Stops playing and opens the disc tray.	All discs
⏸ (pause)	Pauses playback.	All discs
⏮ (previous)/ ⏭ (next)	Goes to the beginning of the previous/next title/ chapter/scene/track.	All discs
⏮⏮⏮/⏭⏭⏭ (fast reverse/fast forward)	Fast reverses/fast forwards the disc when repeatedly pressed during playback. Search speed changes as follows:  <div style="text-align: center;">                     fast reverse      fast forward                      FR1 ←              → FF1                      FR2 ← ←            → → FF2                      FR3 ← ← ←        → → → FF3                      FR4* ← ← ← ←    → → → → FF4*                 </div>	All discs  * FR4 and FF4 are not available for VIDEO CDs.

Buttons	Operations	Discs
 (slow)	Plays in slow motion when pressed repeatedly in pause mode. Playback speed changes as follows:  reverse slow**    forward slow SR1 ←                    → SF1 SR2 ← ←                  → → SF2 SR3 ← ← ←                → → → SF3 SR4 ← ← ← ←              → → → → SF4**	All discs  ** SR1-SR4 and SF4 are not available for VIDEO CDs.
 (instant replay/instant advance)	Replays the scene/briefly fast forwards the scene. ●→ will advance the image frame by frame in pause mode.	
 (audio)	Selects one of the audio tracks recorded on the disc when pressed repeatedly.  <b>DVD</b> : Selects the language.  : Selects one of the recorded audio tracks.	All discs
SUR (Surround)	Switches the Surround effect on ([SUR ON]) or off ([SUR OFF]) when pressed during playback. Surround lets you enjoy virtual surround sound effects created from the front left and right speakers.	All discs
 (subtitle)	Selects a subtitle language when pressed repeatedly.	
 (angle)	Selects an angle when pressed repeatedly. “  ” appears briefly at the scene where the angle to be changed. If various angles (multi-angles) for a scene are recorded on the disc, “  ” appears in the front panel display.	

To resume normal playback, press .

### Notes

- If  appears, the operation is not available on the disc.
- When playing the discs recorded on this recorder, angles and subtitles cannot be changed.
- For a Super VCD, you cannot select audio track 2 if one is recorded on the disc.

### To enlarge a video image (Zoom)

Press ZOOM repeatedly while viewing the picture as follows:

×2 size → ×4 size → normal size

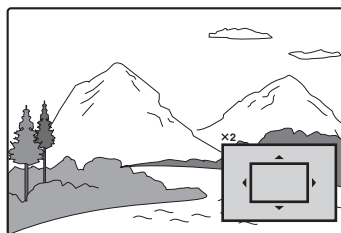

You can move the image using .  
 To resume normal playback, press CLEAR.

### Note

The zoom function may not work depending on the disc.

## To play repeatedly

Press REPEAT repeatedly to select an item to be repeated.

[Chapter]: repeats the current chapter. (DVD only)

[Title]: repeats the current title. (DVD only)

[Track]: repeats the current track. (VIDEO CD only)

[All]: repeats all the tracks on the disc. (VIDEO CD only)

[Off]: does not play repeatedly.

### Notes

- For a VIDEO CD with PBC function, set [PBC] to [Off] in [Settings] Setup (page 74).
- If you press ◀◀/▶▶ (previous/next), ■ (stop), or ◀● (instant replay) during Repeat Play, Repeat Play is cancelled.

## To repeat a specific portion (A-B)

You can play a specific portion of a title, chapter, or track repeatedly.

**1** During playback, when you find the starting point (point A) of the portion to be repeated, press A-B.

[A-] appears on the TV screen.

**2** When you reach the ending point (point B), press A-B again.

[A-B] appears and the recorder starts repeating this specific portion.

To return to normal playback, press A-B to select [Off].

### Note

A-B Repeat Play may not work properly with some Super VCDs.

## To play in random order (VIDEO CD or Karaoke DVD only)

Press RANDOM during playback. [RANDOM] appears on the TV screen.

To return to normal playback, press RANDOM again.

### Hint

To play another title in random order, press ◀◀/▶▶.

### Note

For a VIDEO CD with PBC function, set [PBC] to [Off] in [Settings] Setup (page 74).

## To watch TV in the sub picture during playback (Picture-in-Picture)

You can view a TV programme in the sub picture while playing a disc.

Press  (Picture-in-Picture) during playback to turn on the sub picture on the TV screen.

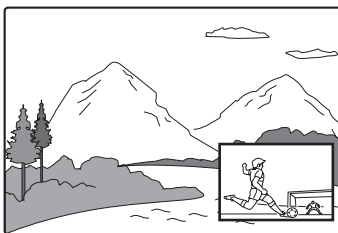

To change the programme position or input source for the sub picture, press PROG +/- or INPUT SELECT.

To change the sub picture position, press ◀/▶. Each press moves the sub picture clockwise or counterclockwise.

To turn off the sub picture, press  again.

### Hint

If you watch TV in full screen, press ■ to stop playback.

## Notes on Surround effect

- The function may not work with some discs.
- When you turn on this function, turn off the surround settings of the connected TV or amplifier (receiver).
- Make sure that your listening position is between and at an equal distance from your speakers, and that the speakers are located in similar surroundings.
- The function does not work if you connect to an amplifier using the DIGITAL OUT (COAXIAL or OPTICAL) jack.

## Note on playing DTS sound tracks on a CD

When playing DTS-encoded CDs, excessive noise will be heard from the analogue stereo jacks. To avoid possible damage to the audio system, the consumer should take proper precautions when the analogue stereo jacks of the recorder are connected to an amplification system. To enjoy DTS Digital Surround™ playback, an external 5.1-channel decoder system must be connected to the digital jack of the recorder.

## Notes on playing DVDs with a DTS sound track

DTS audio signals are output only through the DIGITAL OUT (COAXIAL or OPTICAL) jack.

When you play a DVD with DTS sound tracks, set [DTS] to [On] in [Audio] Setup (page 75).

# Searching for a Title/Chapter/Track, etc.

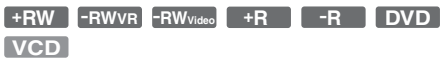

You can search a DVD by title or chapter, and VIDEO CD by track. As titles and tracks are assigned individual numbers on the disc, select the title or track by entering its number. You can also search for a scene using the time code.

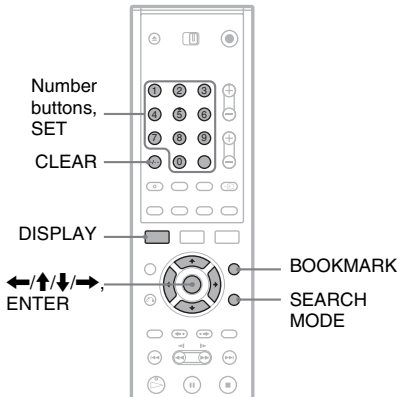

- 1 Press DISPLAY during playback.**  
The on-screen display appears.

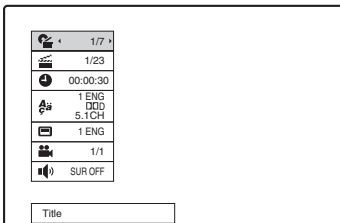

- 2 Select a search item, and press ENTER.**
  - Title (for DVDs)
  - Chapter (for DVDs)
  - Track (for VIDEO CDs with PBC function off)
  - Time (searches for the starting point of entered time code)

- 3 Press the number buttons to select the number of the title, chapter, time code, etc., you want.**

For example: Time search

To find a scene at 2 hours, 10 minutes, and 20 seconds, enter “21020” and press SET.

If you enter the wrong number, press CLEAR to cancel the number, then select another number.

The recorder starts playback from the selected number or scene.

### Hint

You can also search for the item using ◀/▶ in step 3 above. Press ENTER to start playback.

## Bookmarking a favourite scene

You can have the recorder store specific portions of the disc in memory and play immediately whenever you want. Up to nine bookmarks can be set.

### To set a bookmark

During playback, press BOOKMARK when you find a scene to be bookmarked. The bookmark number appears on the TV screen.

### To search for a bookmarked scene

- 1 Press SEARCH MODE.**  
The bookmark search display appears.

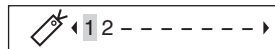

- 2 Press ◀/▶ or the number buttons to select the bookmark number.**  
Playback starts from the bookmarked scene you selected.
- 3 Press SEARCH MODE to turn off the display.**

## To erase the bookmark

- 1 Press SEARCH MODE to turn on the bookmark search display.
- 2 Press  $\leftarrow/\rightarrow$  or the number buttons to select the bookmark number you want to erase, and press CLEAR.
- 3 Press SEARCH MODE to turn off the display.

# Playing Music CDs and MP3 Audio Tracks

CD DATA CD

The recorder can play MP3 audio tracks on DATA CDs (CD-ROMs/CD-Rs/CD-RWs). For details about MP3 audio tracks, see “About MP3 audio tracks” (page 56).

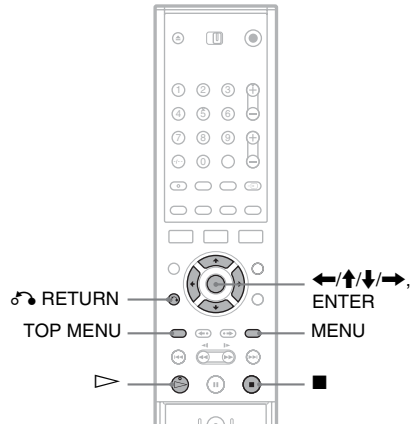

## 1 Insert a disc.

The list menu appears on the TV screen.  
Example: DATA CDs

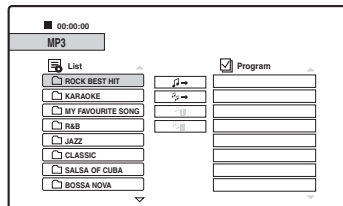

Some CDs automatically start playing from the beginning. When selecting a track, go to step 3.

## 2 Select an album and press ENTER.

The list of tracks within the album appears. To return to the album list, select [ $\square$ ] and press ENTER.

## 3 Select a track and press $\triangleright$ or ENTER.

Playback starts from the selected track.

## To stop playback

Press ■.

When you start playback the next time, the recorder resumes playback from the point where you stopped the track.

Press ■ twice to play from the beginning of the disc/track.

### 💡 Hints

- For CDs, you can also select the track number by pressing the number buttons in step 3 above.
- Press ↑/↓ to go to the next/previous page of the list.
- If you press ↶ RETURN, playback stops and the list menu disappears. To turn on the list menu again, press MENU.
- When the disc contains both MP3 audio tracks and JPEG image files, you can switch between lists. Press TOP MENU, then press ←/→ to select [MP3] or [JPEG] on the top of the menu, and press ENTER.

## Note on playing DTS sound tracks on a CD

When playing DTS-encoded CDs, excessive noise will be heard from the analogue stereo jacks. To avoid possible damage to the audio system, the consumer should take proper precautions when the analogue stereo jacks of the recorder are connected to an amplification system. To enjoy DTS Digital Surround™ playback, an external 5.1-channel decoder system must be connected to the digital jack of the recorder.

## Playback options

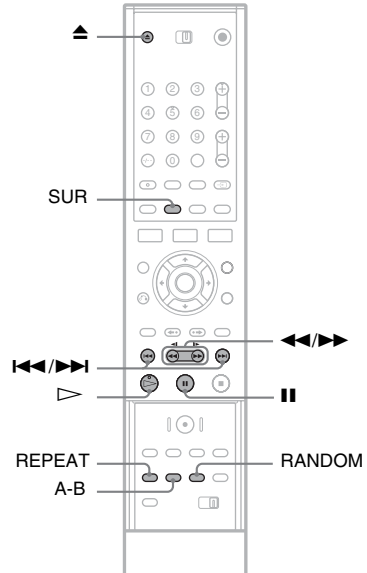

Buttons	Operations
▲ (open/close)	Stops playing and opens the disc tray.
(pause)	Pauses playback.
◀◀/▶▶ (previous/next)	Goes to the beginning of the previous/next track.
◀◀/▶▶ (fast reverse/fast forward) (not available for DATA CDs)	Fast reverses/fast forwards the disc when repeatedly pressed during playback. Search speed changes as follows: Fast reverse    fast forward FR1 ←    → FF1 FR2 ←←    →→ FF2 FR3 ←←←    →→→ FF3
SUR (Surround)	Switches the Surround effect on ([SUR ON]) or off when pressed during playback. Surround lets you enjoy virtual surround sound effects created from the front left and right speakers. (See the notes on Surround effect on page 51.)

Buttons	Operations
RANDOM	Plays tracks in random order when pressed. [Random] appears.
REPEAT	Selects the item to be repeated when pressed repeatedly during playback. [TRACK]: repeats the current track. [ALL]: repeats all the tracks on the disc (CD) or album (DATA CD).
A-B (A-B Repeat)	Selects a specific portion to be repeated when pressed during playback. Press the button to find the starting point (point A) of the portion. [A] appears. Press the button again to reach the ending point (point B). [A-B] appears.

To resume normal playback, press  $\blacktriangleright$ .

To cancel the Surround, Random, Repeat, or A-B Repeat function, press the button again to turn off the indicator.

## Creating your own programme (Programme Play)

You can play the contents of a disc in the order you want by arranging the order of the tracks on the disc. Up to 99 tracks for CDs and 256 tracks for DATA CDs can be programmed. The programme is cleared when the disc is removed.

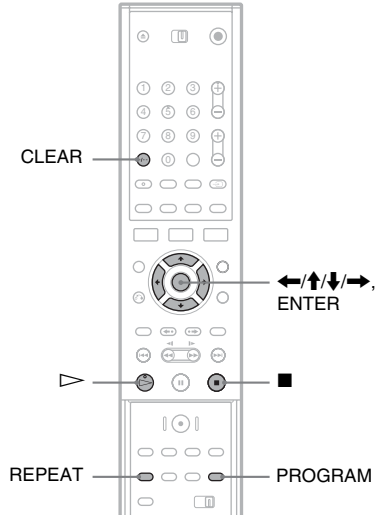

### 1 Insert a disc.

The list menu appears.  
Example: DATA CDs

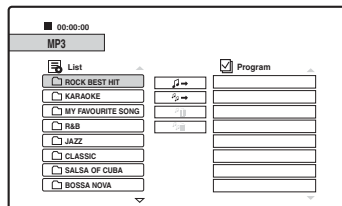

When selecting a track on a music CD, go to step 3.

### 2 Select an album and press ENTER.

### 3 Select the track you want to programme.

### 4 Press PROGRAM, or press $\rightarrow$ to select [ ] (programme) and press ENTER.

The selected track is displayed on [Program] list.

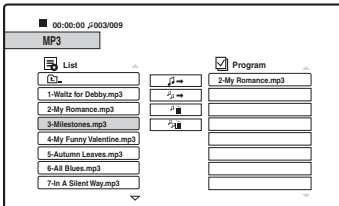

## 5 Repeat steps 2 to 4 to add more tracks to the list.

To add all the tracks on the disc, select [ ] (programme all) and press ENTER.

## 6 Select the track you want to start playing in [Program] list.

## 7 Press or ENTER to start Programme Play.

The tracks in the list are played in the programmed order.

Playback stops after all the tracks in the list are played.

### To erase a track from [Program] list

1 Select the track from [Program] list.

2 Press CLEAR, or select [ ] (erase) and press ENTER.

To erase all the tracks in the list, select [ ] (erase all) and press ENTER.

### To repeat the programme

During Programme Play, press REPEAT to select the item to be repeated.

[TRACK]: repeats the current track.

[ALL]: repeats all the tracks on the list.

No display: does not play repeatedly.

### To stop playback during Programme Play

Press .

## About MP3 audio tracks

MP3 is audio compression technology that satisfies certain ISO/MPEG regulations.

You can play back DATA CDs (CD-ROMs/CD-Rs/CD-RWs) recorded in MP3 (MPEG1 Audio Layer 3) format. However, the discs must be recorded according to ISO9660 Level 1, Level 2, or Joliet format for the recorder to recognize the tracks. You can also play discs recorded in Multi Session.

See the instructions supplied with the CD-R/CD-RW drives and the recording software (not supplied) for details on the recording format.

### Hints

- Playback stops when all the MP3 audio tracks within the album are played.
- Since a disc with many trees takes longer to start playback, it is recommended that you create albums with no more than two trees.

### Notes

- The recorder may not be able to play some DATA CDs created in the Packet Write format.
- The recorder will play any data with the extension “.MP3,” even if they are not in MP3 format. Playing this data may generate a loud noise which could damage your speaker system.
- The recorder does not conform to audio tracks in MP3PRO format.
- The recorder can recognize up to a total number of 999 albums and tracks in a DATA CD. The recorder may not recognize some discs depending on the recording device used for recording or the disc condition.
- The recorder can play MP3 audio tracks recorded in the following sampling frequencies: 32 kHz, 44.1 kHz, 48 kHz.
- Only the letters in the alphabet and numbers can be used for album or track names.
- ID3 tags cannot be displayed.



# Playing JPEG Image Files

## DATA CD

You can play JPEG image files on DATA CDs (CD-Rs/CD-RWs). For details about JPEG image files, see “About JPEG image files” (page 58).

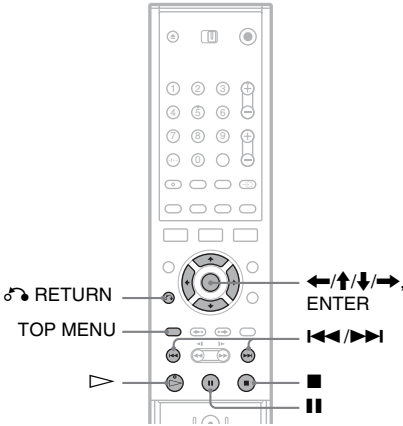

## 1 Insert a DATA CD.

The list menu appears on the TV screen.

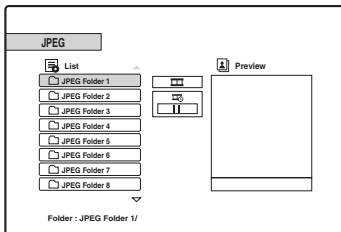

When the disc contains both MP3 audio tracks and JPEG image files, you can switch between lists. Press TOP MENU. Press ←/→ to select [JPEG] on the top of the menu and press ENTER.

## 2 Select a folder, and press ENTER.

The list of files within the folder appears. To return to the folder list, select [ ] and press ENTER.

## 3 Select the file you want to view.

The selected image is displayed in the preview window.

- If you set a slide show speed mode ( ) other than [ ] (off), the slide show starts from the selected file. See “Enjoying a slide show” below.

## 4 Press ▷ or ENTER.

The selected image is displayed in full screen.

### To rotate a image

Press ↑/↓ while viewing the image. Each press rotates the image clockwise or counterclockwise by 90 degrees.

### To view the previous or next image

Press ◀▶/▶▶ or ◀▶/▶▶.

### To return to the list menu

Press ■.

### 💡 Hints

- Press ↑/↓ to go to the next/previous page of the list.
- Press ↶ RETURN repeatedly to turn off the list menu. To turn on the list menu, press MENU.

## Enjoying a slide show

You can play JPEG image files on a DATA CD successively as a slide show.

## 1 Select the folder you want to view, and press ENTER.

## 2 Press → to select [ ] (slide show).

## 3 Press ↓ to select [ ] (play speed).

## 4 Press ←/→ to select a playing speed, >>> (fast), >> (normal), or > (slow), and press ENTER.

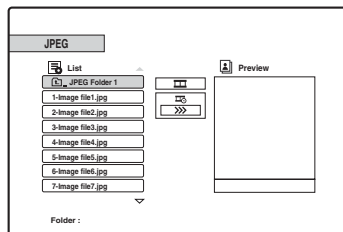

## 5 Select a file and press $\triangleright$ or ENTER.

Slide show starts from the selected image file.

To pause playback, press **II**.

To stop the slide show and return to the list menu, press **■** or  $\curvearrowright$  RETURN.

---

## About JPEG image files

JPEG is image compression technology.

You can play back DATA CDs (CD-ROMs/CD-Rs/CD-RWs) recorded in JPEG format. However, the discs must be recorded according to ISO9660 Level 1, Level 2, or Joliet format for the recorder to recognize the files.

You can also play discs recorded in Multi Session. See the instructions supplied with the CD-R/CD-RW drives and the recording software (not supplied) for details on the recording format.

### Hints

- If you add numbers (01, 02, 03, etc.) to the front of the files, the files will be played in that order.
- Since a disc with many trees takes longer to start playback, it is recommended that you create folders with no more than two trees.

### Notes

- The recorder can only play files with the extension “.JPG.”
- The recorder can recognize up to a total number of 999 folders and files in a disc. The recorder may not recognize some discs depending on the recording device used for recording or the disc condition.
- Depending on the disc or the size of image files, playback may take some time to start.
- The image size that the recorder can display is limited to  $8192 \times 7680$  pixels.
- Progressive and lossless compression JPEG image files are not supported.

## Erasing and Editing

## Before Editing

This recorder offers various edit options for various disc and title types. Before you edit, check these types and select an available option.

### Notes

- You may lose edited contents if you remove the disc while editing.
- Finish editing and recording before finalizing. No more editing or recording can be made on a finalized disc.
- If a message appears and indicates that the disc's control information is full, erase unnecessary titles.

## Edits for Video mode titles/original titles

+RW   -RWVR   -RW<sub>video</sub>   +R   -R

For Video mode titles on DVD+RWs/DVD-RWs (Video mode)/DVD+Rs/ DVD-Rs, and original titles on DVD-RWs (VR mode), the recorder edits actual recordings on the disc. You cannot undo any edits you make, and the original contents will be consequently lost.

### Hint

When using a DVD-RW (VR mode), you can keep the original contents by editing a Playlist (see "Edits for Playlist titles" below).

## To free up disc space (DVD+RW/DVD-RW (VR mode)/DVD-RW (Video mode) only)

You can utilize disc capacity by erasing Video mode or original titles. The effect differs depending on the disc type and location of the title, as follows.

Disc type	To open up disc space
DVD+RW	Erase the last title on the disc. You can erase and overwrite titles other than the last one; however, the display will not show the resulting capacity increase. Erased titles are shown as deleted in the Title List menu.
DVD-RW (VR mode)	Erase original titles anywhere on the disc.
DVD-RW (Video mode)	Erase the last title on the disc.
DVD+R/ DVD-R	You cannot increase the disc capacity, as they are non-rewritable.

### Note

For DVD+RWs and DVD-RWs (VR mode), the disc's available capacity may not display correctly. The recorder displays only the available capacity after the last title on the disc.

## Edits for Playlist titles

-RWVR

For DVD-RWs (VR mode), you can edit a Playlist while retaining original titles (actual recordings on the disc). A Playlist is a group of Playlist titles created from the original title for editing purposes. When you create a Playlist, only the control information necessary for playback, such as the playback order, is stored on the disc. Since the original titles are left unaltered, Playlist titles can be re-edited.

Example: You have recorded the final few matches of a football tournament on a DVD-RW (VR mode). You want to create a digest with the goal scenes and other highlights, but you also want to keep the original recording.

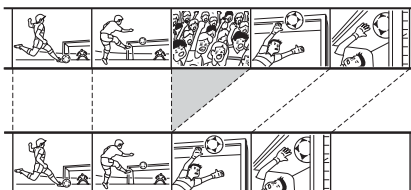

In this case, you can select a title or chapter and create a Playlist title. You can even rearrange the scene order within the Playlist title (page 65).

**Hint**

For DVD-RW (VR mode), you can display the disc's Playlist titles in Title List (Playlist), or the original titles in Title List (Original). Press TITLE LIST repeatedly to switch the two Title List menus.

**List of edit options**

Select from the following options and refer to the pages in parentheses. Title type and disc type that the option can be applied are indicated in each section.

- Labelling a title (page 61).
- Erasing a title (page 61).
- Erasing a section of a title (A-B Erase) (page 61).
- Protecting a title (page 62).
- Dividing a title (page 62).
- Erasing a chapter (page 63).
- Combining chapters (page 63).
- Hiding a chapter (page 64).
- Creating chapters manually (page 64).
- Creating a Playlist title (page 64).
- Adding contents to an existing Playlist title (page 65).
- Rearranging chapters within a Playlist title (page 65).

**Note**

When selecting a title for editing, always note the above differences between the Video mode/original title edit and Playlist title edit.

**Erasing and Editing Titles**

This section explains the basic edit functions common to Video mode titles, original titles, and Playlist titles.

Note that editing on Video mode and original titles is irreversible as they are the actual recordings on the disc. If you want to edit a DVD-RW (VR mode) while retaining the original contents, create and edit a Playlist (page 64).

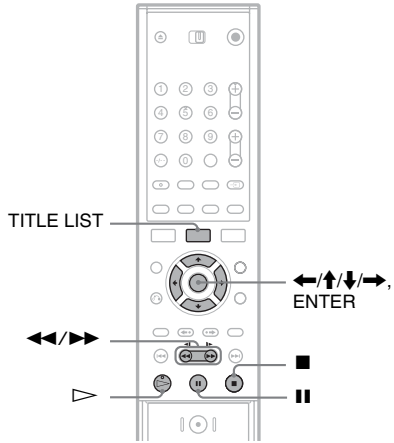

**Note**

If you edit an original title after creating a Playlist title, the edits may affect the derived Playlist title.

**1 Press TITLE LIST to turn on the Title List.**

The Title List menu appears and displays the disc contents.

When editing a DVD-RW (VR mode), press TITLE LIST repeatedly to switch the Title List (Original) and Title List (Playlist), if necessary.

Example: Title List (Original)

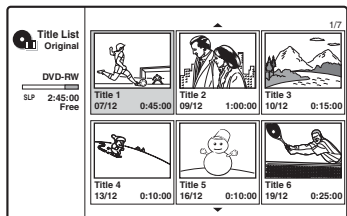

## 2 Select a title, and press ENTER.

The sub-menu appears with options available for the selected title.

[Chapter List]: Displays the Chapter List menu, which displays the title contents by chapter (see “Editing a Title by Chapter” on page 63).

[Erase]: Erases the title (page 61). For effects on disc capacity, see page 59.

[Protect]: Protects the title from erasure or alteration (page 62).

[Edit]: Displays the following options.

[Title Name]: Allows you to label the title (page 61).

[Divide]: Divides the title in two (page 62).

[A-B Erase]: Erases a section of the title (page 61).

[Playlist]: Allows you to create a new Playlist title, or add contents to an existing Playlist title (see “Editing a Playlist” on page 64).

## 3 Select an edit option, and press ENTER.

The selected option is applied to the title. See the pages in parentheses for the procedure.

### Labelling a title

+RW -RWVR -RWVideo +R -R

## 1 Select [Edit] in step 3 of “Erasing and Editing Titles,” and press ENTER.

## 2 Select [Title Name], and press ENTER.

The display for entering characters appears. You can enter up to 21 characters. Follow the explanations of “Changing the Name of a Recorded Programme (Title Input)” (page 32).

### Hint

You can label or re-label DVDs (page 34).

### Erasing a title

+RW -RWVR -RWVideo +R -R

## 1 Select [Erase] in step 3 of “Erasing and Editing Titles,” and press ENTER.

The display asks for confirmation.

## 2 Select [OK], and press ENTER.

The title is erased.

### Hints

- When you want to erase all titles, reformat the disc (page 27).
- After deleting a title on a DVD+RW, the title name is displayed as deleted in the Title List menu. You can select it to record over.

### Erasing a section of a title (A-B Erase)

-RWVR

## 1 Select [Edit] in step 3 of “Erasing and Editing Titles,” and press ENTER.

## 2 Select [A-B Erase], and press ENTER.

The following display appears.

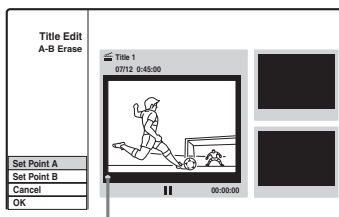

Current playback point

## 3 Press $\triangleright$ , and search for the scene you want to erase by pressing $\blacksquare$ , $\text{II}$ , and $\blacktriangleleft$ / $\blacktriangleright$ .

- Press ENTER at the start of the scene to be erased (point A).

Thumbnail of point A

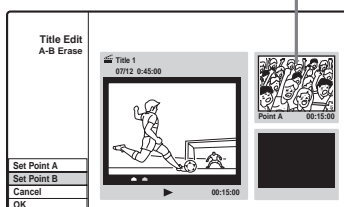

- Press ENTER at the end of the scene (point B).

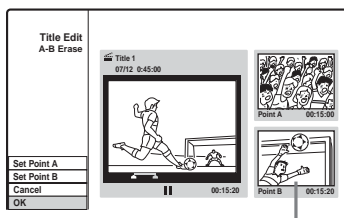

Thumbnail of point B

To reset either point A or B, select [Cancel] and repeat from step 3.

- Select [OK], and press ENTER. The display asks for confirmation. If you do not want to erase the scene, select [Cancel] and press ENTER.
- Select [OK], and press ENTER. The scene is erased.

## Notes

- Images or sound may be momentarily interrupted at the point where you erase the scene.
- Sections shorter than five seconds may not be erased.
- The erased section may be slightly different from the points you selected.
- A chapter mark will not be made at the A–B erase point.

## Protecting a title from erasure or alteration

+RW +R

Select [Protect] in step 3 of “Erasing and Editing Titles,” and press ENTER.

The title is protected and [🔒] (locked) appears in the Title List menu.

To cancel the protection, select [Protect] again.

## Dividing a title

+RW

- Select [Edit] in step 3 of “Erasing and Editing Titles,” and press ENTER.

- Select [Divide], and press ENTER.

The display for setting the dividing point appears.

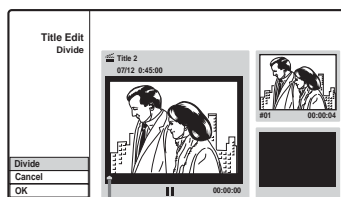

Current playback point

- Press ▷, and search for the point you want to divide by pressing ■, ||, and ◀▶.
- Press ENTER at the dividing point. To reset the point, select [Cancel] and repeat from step 3.
- Select [OK], and press ENTER. The title is divided in two. If you want to rename the title, see page 61. If you do not want to divide the title, select [Cancel] and press ENTER.

## Editing a Title by Chapter

You can make detailed editing to a title by using the Chapter List menu that displays title contents by chapter.

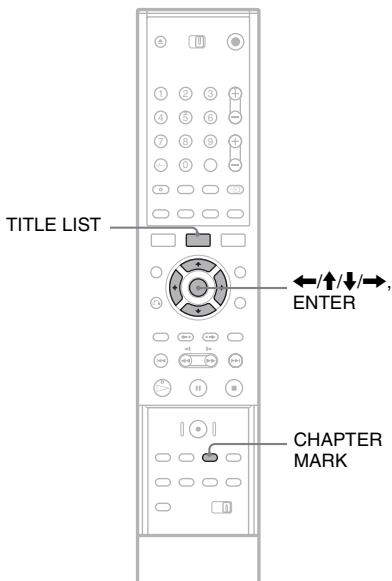

- 1 Press TITLE LIST to turn on the Title List.**  
When editing a DVD-RW (VR mode), press TITLE LIST repeatedly to switch the Title List (Original) and Title List (Playlist), if necessary.
- 2 Select a title, and press ENTER.**  
The sub-menu appears.
- 3 Select [Chapter List], and press ENTER.**  
The Chapter List menu appears with contents of the selected title (displayed as chapters).

Example: Chapter List (Original)

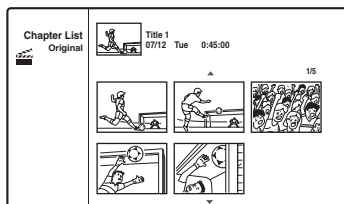

### 4 Select a chapter, and press ENTER.

The sub-menu appears with options available for the selected chapter.

[Title List]: Displays the Title List menu (see “Erasing and Editing Titles” on page 60).

[Erase]: Erases the chapter (page 63).

[Edit]: Displays the following options.

[Combine]: Combines two chapters into one (page 63).

[Hide/Show]: Hides the chapter/Shows the hidden chapter (page 64).

[Move]: Allows you to change the chapter order within the title. Follow the same instructions in step 6 of

“Rearranging chapters within a Playlist title” (page 65).

### 5 Select an edit option, and press ENTER.

The selected option is applied to the chapter. See the pages in parentheses for the procedure.

## Erasing a chapter

-RWVR

- 1 Select [Erase] in step 5 of “Editing a Title by Chapter,” and press ENTER.**  
The display asks for confirmation.
- 2 Select [OK], and press ENTER.**  
The chapter is erased.

## Combining chapters

+RW -RWVR +R

- 1 Select [Edit] in step 5 of “Editing a Title by Chapter,” and press ENTER.**
- 2 Select [Combine] and press ENTER.**  
The selected chapter is combined with the next chapter in the Title List.

### Note

If the next chapter on the DVD+RW or DVD+R is hidden, show the chapter in the Title List before combining. See “Hiding a chapter” (page 64).

---

## Hiding a chapter

+RW

+R

You can skip playing chapters without deleting from the disc.

**1** Select [Edit] in step 5 of “Editing a Title by Chapter,” and press ENTER.

**2** Select [Hide], and press ENTER.

The chapter is displayed shaded in the Chapter List menu.

---

### To play a title including hidden chapters

Select [Full Play] in step 3 of “Editing a Title by Chapter,” and press ENTER.

### To show the chapter

Repeat the steps above and select [Show] in step 2.

#### Notes

- Images or sound may be momentarily interrupted at the point where you hide the chapter.
  - On other Sony DVD equipment, hidden chapters will play without being skipped.
- 

## Creating chapters manually

+RW

-RWvR

+R

You can create chapters within a title by inserting chapter marks at the desired points.

**During playback, press CHAPTER MARK where you want to divide the title into chapters.**

The following display appears at the dividing point. Title contents before and after this scene become separate chapters.



#### Hint

You can combine two chapters into one (page 63).

#### Note

If a message appears and indicates that no more chapter marks can be added, you may not be able to record or edit.

---

## Editing a Playlist

-RWvR

Playlist edit allows you to edit or re-edit without changing the actual recordings.

This section explains edit options available only for Playlist titles. Edits explained in the previous sections are also applicable if so indicated.

#### Notes

- If you edit an original title after creating a Playlist title, the results may affect the derived Playlist title.
- The picture may pause when an edited scene is played.

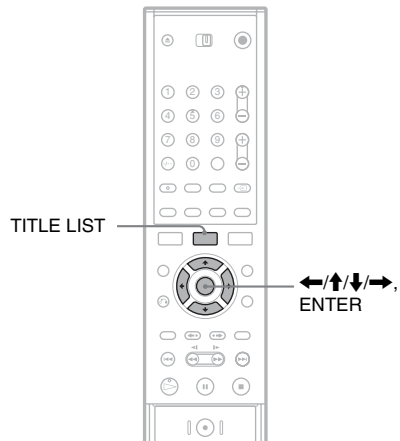

---

## Creating a Playlist Title

**1** Press TITLE LIST to turn on the Title List (Original).

Press TITLE LIST again if the Title List (Playlist) appears.

**2** Select a title, and press ENTER.

The sub-menu appears.

[Playlist]: Displays Playlist title names in the Title List (Playlist) menu.

[Chapter List]: Displays the Chapter List (Original) menu. When you want to add an original chapter as a Playlist title, select this and press ENTER. After the Chapter List (Original) menu appears, select the chapter and press ENTER, and then go to step 3.

**3** Select [Playlist], and press ENTER.



- 4 Select [New Playlist], and press ENTER.**  
The title or chapter is added to the Playlist as a new Playlist title.  
To create more Playlist titles, press TITLE LIST and repeat the steps above.

## Adding contents to an existing Playlist title

- 1 Press TITLE LIST to turn on the Title List (Original).**  
Press TITLE LIST again if the Title List (Playlist) appears.
- 2 Select a title, and press ENTER.**  
The sub-menu appears.  
[Playlist]: Displays Playlist title names in the Title List (Playlist) menu.  
[Chapter List]: Displays the Chapter List (Original) menu. When you want to add an original chapter to a Playlist title, select this and press ENTER. After the Chapter List (Original) menu appears, select the chapter and press ENTER, and then go to step 3.
- 3 Select [Playlist], and press ENTER.**  
The disc's Playlist title names appear (if any).

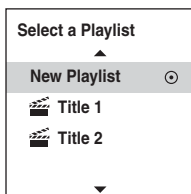

- 4 Select a Playlist title name, and press ENTER.**  
The contents of original title selected in step 2 are added to the Playlist title. If you want to rename the title, see page 61. You can enter up to 21 characters.

## Rearranging chapters within a Playlist title

You can move chapters in a Playlist title to create a different playback order.

- 1 Press TITLE LIST to turn on the Title List (Playlist).**  
Press TITLE LIST again if the Title List (Original) appears.

- 2 Select a title, and press ENTER.**  
The sub-menu appears.
- 3 Select [Chapter List], and press ENTER.**  
The Chapter List menu appears with the title contents.

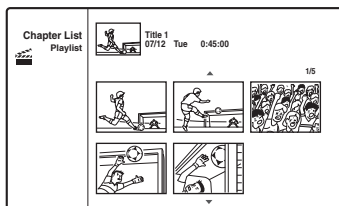

- 4 Select a chapter, and press ENTER.**  
The sub-menu appears with options available for the selected chapter. For details, see “Editing a Title by Chapter” (page 63).
- 5 Select [Edit] and press ENTER.**
- 6 Select [Move], and press ENTER.**
- 7 Select a new location in the Chapter List, and press ENTER.**  
The chapter moves to the new location.  
To change the scene order more, repeat the steps above.  
If you want to rename the title, see page 61.

### Note

Images or sound may be momentarily interrupted at the point where the chapters change.

# Connecting a Digital Video Camera to the DV IN Jack

## Before DV Dubbing

This section explains dubbing with a digital video camera via the DV IN jack on the front panel. If you want to dub by way of the LINE IN jacks, see “Recording From Connected Equipment” (page 45).

### To record from the DV IN jack

The DV IN jack on this recorder conforms to the i.LINK standard. You can connect any other equipment that has an i.LINK (DV) jack, and record digital signals.

Follow the instructions in “Connecting a Digital Video Camera to the DV IN Jack,” and then move on to the section on dubbing. For more information about i.LINK, see “About i.LINK” (page 85).

### Hint

If you plan to do additional editing on a disc after the initial dub, use the DV IN jack and record on a DVD-RW (VR mode).

You can connect a digital video camera to the DV IN jack on the recorder to record or edit from a DV/Digital8 format tape. Operation is straightforward because the recorder will fast forward and rewind the tape for you – you do not need to operate your digital video camera. Do the following to start using the “DV Edit” functions of this recorder.

See also the instruction manual supplied with the digital video camera before connecting.

### Notes

- The DV IN jack is for input only. It will not output signals.
- You cannot use the DV IN jack when:
  - your digital video camera does not work with this recorder. Connect the camera to the LINE IN jack and follow the instructions of “Recording From Connected Equipment” (page 45).
  - the input signal is not in DVC-SD format. Do not connect a MICRO MV format digital video camera even if it has an i.LINK jack.
  - the images on the tape contain copy protection signals, which limit recording.
- If you want to play the disc on other DVD equipment, finalize the disc (page 35).

### Hookups

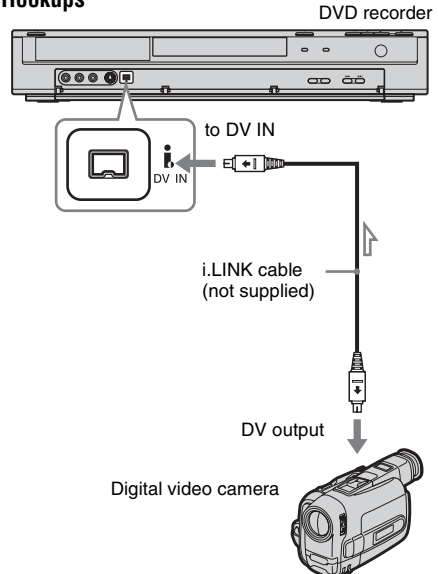

 : Signal flow

# Dubbing From a DV/Digital8 Format Tape to a DVD

**+RW** **-RWVR** **-RWVideo** **+R** **-R**

You can record a DV/Digital8 format tape onto a disc. The recorder controls the digital video camera. You can fast forward, rewind, and stop the tape to select a scene using the recorder's remote control.

## ◆How chapters are created

The dubbed contents become one title, and the title is divided into chapters. The recorder divides the title into chapters according to the setting in [Rec Setting] Setup (5, 10, or 15-minute intervals, or does not divide at all) (page 77).

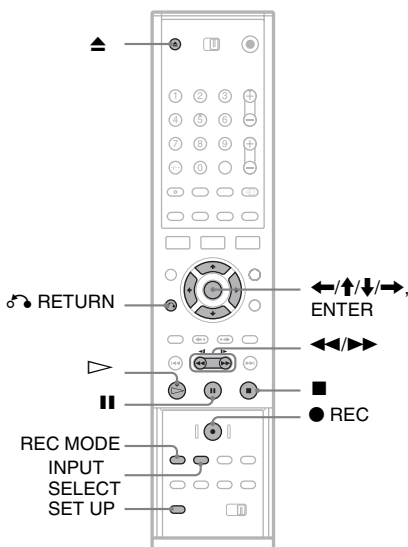

## 1 Press **▲** (open/close), and place a recordable disc on the tray.

Make sure that the disc has enough free space to record the contents of your tape.

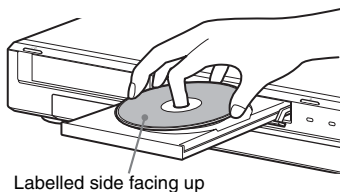

## 2 Press **▲** (open/close) to close the disc tray.

Wait until "LOADING" disappears from the front panel display.

For details on how to insert and format a new disc, see "Inserting and Formatting a Disc" (page 27).

## 3 Insert the source DV/Digital8 format tape into your digital video camera.

For the recorder to record or edit, your digital video camera must be turned on and set to video playback mode.

## 4 Press **INPUT SELECT** on the remote repeatedly to select "DV."

The selected input changes as follows:

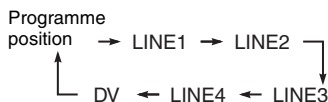

## 5 Press **REC MODE** on the remote repeatedly to select the recording mode.

The recording mode changes as follows:

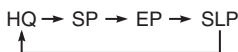

For details about the recording modes, see page 37.

## 6 Press **SET UP** on the remote.

The Setup Display appears.

## 7 Select **[Rec Setting]**, and press **➡**.

## 8 Select **[DV Audio Input]**, and press **➡**.

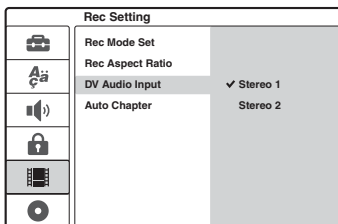

[Stereo 1] (default): Records original sound only. Normally select this when dubbing a DV format tape.



[Stereo 2]: Records additional sound only. Select this only if you have added a second audio channel when recording with your digital video camera.

## 9 Select an option, and press **ENTER**.

**10** Press  RETURN to turn off the Setup Display.

**11** Press  to start playing the DV/Digital8 format tape.

The playback picture appears on the screen.

**12** While watching the screen, search for the point you want to start recording by pressing  .

**13** When you find the point you want, press .

**14** Press  REC.

Playback starts from the selected point, and the recorder starts recording.

---

## To stop recording

Press . Note that it may take a few seconds for the recorder to stop recording.

### Notes

- If you want to play the disc on other DVD equipment, finalize the disc (page 35).
- You cannot connect more than one piece of digital video equipment to the recorder.
- You cannot control the recorder using another device or another recorder of the same model.
- You cannot record date, time, or the contents of the cassette memory onto the disc.
- When dubbing from a DV/Digital8 format tape by way of the DV IN jack, the recorder starts recording about five seconds after the tape starts playing.
- If you dub a DV/Digital8 format tape that has been edited on a PC using the DV IN jack, any audio recorded on the Stereo 2 track may only be recorded as noise.
- If you record from a DV/Digital8 format tape with a sound track that is recorded in multiple sampling frequencies (48 kHz, 44.1 kHz, or 32 kHz), no sound or an unnatural sound will be output when playing back the sampling frequency switch point on the disc.
- The recorded picture may be momentarily affected if the picture size of the source image changes, or if there is nothing recorded on the tape.
- When dubbing from the DV IN jack, pictures are recorded only in 4:3 size regardless of the [Rec Aspect Ratio] setting in [Rec Setting] Setup (page 77). You can select the picture size for DVD-RWs (VR mode) only.
- Noise may occur when you switch the audio sampling mode (e.g. 48 kHz/16 bits → 32 kHz/12 bits).
- The video or sound may drop out during the recording of start/stop points on the tape.
- If there is a blank space for one second or more on the tape, DV dubbing ends automatically.

# Using the Setup Displays

By using the Setup Displays, you can make various adjustments to items such as picture and sound, as well as select a language for the subtitles.

The Setup Display consists of several levels to set up options. To select the next level, press **→**. To select a previous level, press **←**.

**Note**

Playback settings stored in the disc take priority over the Setup Display settings, and not all of the functions described may work.

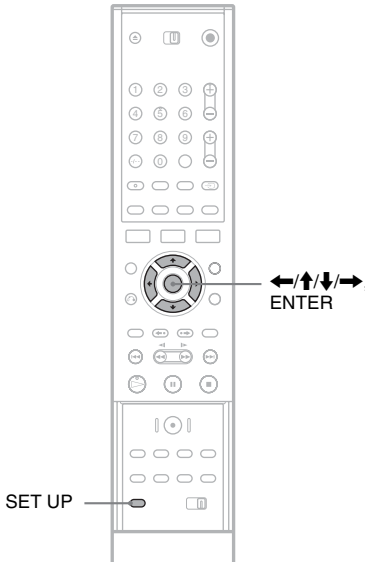

## 1 Press SET UP while the recorder is in stop mode.

The Setup Display appears.

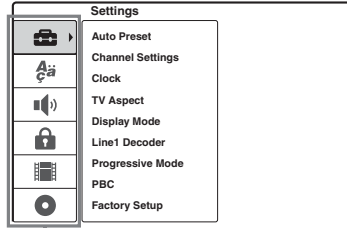

Setup options:  
[Settings], [Language], [Audio], [Parental Control], [Rec Setting], [Disc Info]

For details about [Disc Info] Setup, see “Basic Operation” (page 27).

## 2 Press ↑/↓ to select the option you want to set up, and press →.

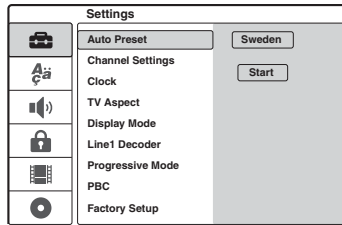

## 3 Press ↑/↓ to select the item you want to set up, and press →.

Available options for the item appear.  
Example: [TV Aspect]

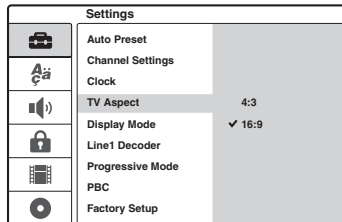

- 4** Press **↑/↓** to select the item you want to set up, and press **ENTER** to conform.  
Some items require additional settings.

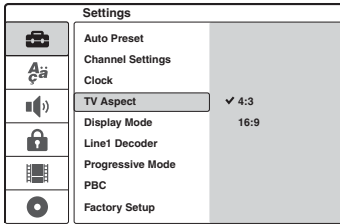

### To turn off the Setup Display

Press **SET UP**.

## Channel and Clock Settings

The [Settings] Setup helps you to make tuner, clock, and channel settings for the recorder.

Select  [Settings] in the Setup Display. To use the display, see “Using the Setup Displays” (page 69).

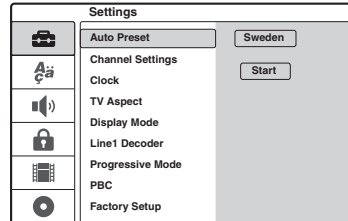

### [Auto Preset]

Presets all receivable channels automatically.  
Select your country. Then select [Start] and press **ENTER**.

### [Channel Settings]

Presets channels manually.  
If some channels could not be set using the Auto Preset function, you can set them manually.  
If there is no sound or if the picture is distorted, the wrong tuner system may have been preset during [Auto Preset]. Set the correct tuner system manually in the steps below.

- 1** Select [Channel Settings] and press **→**.

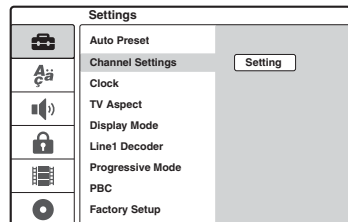

- 2 Press ENTER while [Setting] is selected. The Channel List menu appears.

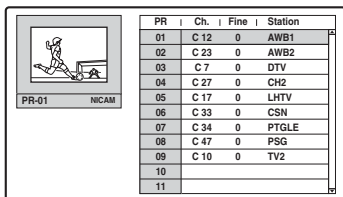

- 3 Press  $\uparrow/\downarrow$  to select the programme position you want to set, and press ENTER.

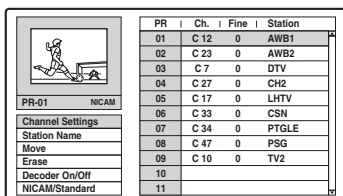

- 4 Select an option from the sub-menu, and press ENTER.

[Channel Settings]: Sets the channel manually. See “To set the channels manually” below.

[Station Name]: Changes the station name. The display for entering characters appears. To enter characters, see page 32.

[Move]: Sorts the programme positions on the Channel List. Press  $\uparrow/\downarrow$  to move the selected programme position to a new location.

[Erase]: Disables a programme position you do not need.

[Decoder On/Off]: Sets the channels for the decoder. You need this setting to watch or record PAY-TV/Canal Plus programmes. Press ENTER so [Decoder] appears on the display. Press ENTER again to turn off the setting.

[NICAM/Standard]: Sets the channels for the NICAM broadcast. Normally, [NICAM] is lit on the display. If the sound from NICAM broadcast is not clear, press ENTER so [NICAM] disappears.

### Note

Be sure to correctly select the programme position you want to disable. If you disable the wrong programme position by mistake, you need to reset that channel manually.

### ◆To set the channels manually

When you select [Channel Settings] in step 4 above, the display for setting channels appears.

- 1 Press  $\leftarrow/\rightarrow$  to select the item and press  $\uparrow/\downarrow$  to change the setting. [PR] indicates the selected programme position.

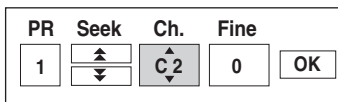

[Seek]: Searches for a channel automatically. Searching stops when the recorder tunes in a channel.

[Ch.]: Changes the channel number.

[Fine]: Fine tunes the channel to obtain a clearer picture.

[PAL/SECAM]: This appears only for selected models. For customers in France, switch channels from PAL to SECAM if the reception is poor.

- 2 Select [OK] and press ENTER. The setting is stored and the display returns to the Channel List. To preset other channels, follow from step 3 of the Channel List setting (page 70).

### ◆Receivable channels

TV system	Channel coverage
BG (West European Countries, except those listed below) Colour system: PAL	E2 - E12 VHF
	Italia A - H VHF
	E21 - E69 UHF
	S1 - S20 CATV
	S21 - S41 HYPER
DK (East European Countries) Colour system: PAL	S01 - S05 CATV
	R1 - R12 VHF
	R21 - R69 UHF
	S1 - S20 CATV
	S21 - S41 HYPER
	S01 - S05 CATV

TV system	Channel coverage
I (Great Britain/ Ireland) Colour system: PAL	Ireland A – J VHF
	South Africa 4 – 13 VHF
	B21 – B69 UHF
	S1 – S20 CATV
	S21 – S41 HYPER
	S01 – S05 CATV
L (France) Colour system: SECAM	F2 – F10 VHF
	F21 – F69 UHF
	B – Q CATV
	S21 – S41 HYPER

- 3 Press **↑/↓** to set the day, and press **→**.  
Set the month, year, hour, and minutes in sequence. Press **←/→** to select the item to be set, then press **↑/↓** to set the numbers.

To change the numbers, press **←** to return to the item to be changed, and press **↑/↓**.

- 4 Press **ENTER** to start the clock.

## [Clock]

### ◆[Auto Adjust]

Turns on the Auto Clock Set function when a channel in your local area broadcasts a time signal.

- 1 Select [Clock] and press **→**.

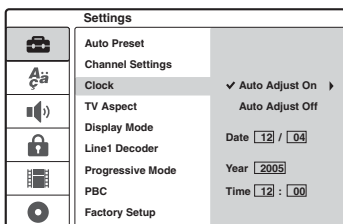

- 2 Select [Auto Adjust On] and press **ENTER**.

### 💡 Hint

If you select [Auto Adjust On], the Auto Clock Set function is activated whenever the recorder is turned off.

### ◆To set the clock manually

If the Auto Clock Set function did not set the clock correctly for your local area, set the clock manually.

- 1 Select [Clock] and press **→**.

- 2 Press **→**.

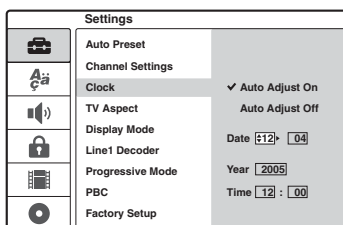



# TV and Video Settings

These settings will adjust items related to the image, such as size.

Choose the settings according to the type of TV, tuner, or decoder connected to the recorder.

Select  [Settings] in the Setup Display. To use the display, see “Using the Setup Displays” (page 69). The default settings are underlined.

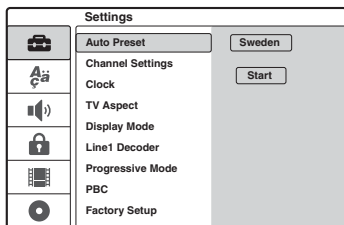

## [TV Aspect]

Selects the aspect ratio of the connected TV (4:3 standard or wide).

[ <u>4:3</u> ]	Select this when connecting to a 4:3 screen TV. When you select [4:3], set [Display Mode] below.
[ <u>16:9</u> ]	Select this when connecting to a wide-screen TV or TV with a wide mode function.

## [Display Mode]

Selects how to display a wide picture on the screen when [4:3] is selected in [TV Aspect].

[ <u>Letter Box</u> ]	Displays a wide picture with bands on the upper and lower portions of the screen.
[ <u>Pan Scan</u> ]	Automatically displays a wide picture on the entire screen and cuts off the portions that do not fit.

[16:9]



[4:3 Letter Box]



[4:3 Pan Scan]

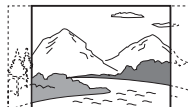

## Note

Depending on the disc, [Letter Box] may be selected automatically instead of [Pan Scan] or vice versa.

## [Line1 Decoder]

Sets the LINE 1-TV jack for inputting encoded video signals.

[ <u>Off</u> ]	Inputs the signals from the LINE 1-TV jack. Normally select this.
[ <u>On</u> ]	The signal input from the LINE 1-TV jack is output to the LINE 3/DECODER jack so you can record or view PAY-TV/Canal Plus programmes. In this case, select “LINE 1” by pressing INPUT SELECT.

## [Progressive Mode] (Viewing in Progressive format)

Selects whether the COMPONENT VIDEO OUT jacks output progressive signals.

[ <u>Off</u> ]	Select this when your TV is not compatible with progressive signals, or, the TV is connected to jacks other than the COMPONENT VIDEO OUT jacks.
[ <u>On</u> ]	Select this when your TV accepts progressive 625p format signals, and, the TV is connected to the COMPONENT VIDEO OUT jacks. You will enjoy accurate colour reproduction and high quality image.

## Notes

- You cannot select [On] if the VIDEO OUT SELECT switch on the rear panel is set to “RGB” (page 15). Make sure that it is set to “COMPONENT.”
- When set to [On], pictures appear on a progressive compatible TV or monitor. Signals are only sent to the COMPONENT VIDEO OUT jacks in progressive mode. To cancel the setting, remove the disc and close the disc tray. Then press and hold **■** (stop) on the recorder for five seconds.
- If your TV does not accept progressive signals, [Progressive Mode] will be set to [Off] automatically after a few seconds.

## [PBC] (Playback Control)

Turns the PBC function on or off when playing VIDEO CDs.

---

[ Off ]	The PBC function is not activated. VIDEO CDs with PBC will be played the same way as audio CDs.
---------	---

---

[ <u>On</u> ]	The PBC function is activated when playing VIDEO CDs with PBC.
---------------	--

---

## Language Settings

The [Language] Setup allows you to select a language for the recorder’s display and discs.

Select **Aa** [Language] in the Setup Display. To use the display, see “Using the Setup Displays” (page 69).

The default settings are underlined.

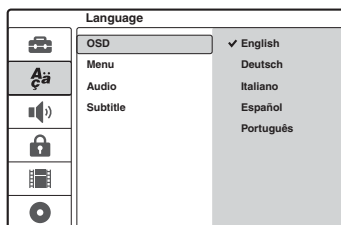

## [OSD] (On-Screen Display)

Switches the display language on the screen.

## [Menu] (DVD VIDEO only)

Switches the language for the DVD menu.

## [Audio] (DVD VIDEO only)

Switches the language of the sound track.

## [Subtitle] (DVD VIDEO only)

Switches the language of the subtitles recorded on the disc.

---

[ <u>Original</u> ]	Selects the language given priority in the disc.
---------------------	--

---

[ Other ]	The display for entering a language code appears. Press the number buttons to enter a four-digit code number from “Language Code List” (page 92) and press ENTER.
-----------	---

---

## Note

If you select a language in [Menu], [Subtitle], or [Audio] that is not recorded on the DVD VIDEO, one of the recorded languages will be automatically selected.

# Audio Settings

The [Audio] Setup allows you to adjust the sound according to the playback and connection conditions.

Select  [Audio] in the Setup Display. To use the display, see “Using the Setup Displays” (page 69). The default settings are underlined.

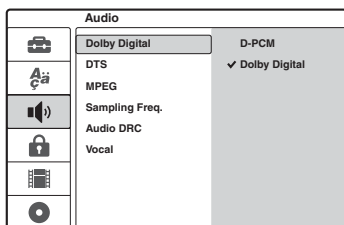

## [Dolby Digital] (DVDs only)

Selects the type of Dolby Digital signal when using the DIGITAL OUT (OPTICAL or COAXIAL) jack.

---

[ D-PCM ] Select this when the recorder is connected to an audio component without a built-in Dolby Digital decoder.

---

[ Dolby Digital ] Select this when the recorder is connected to an audio component with a built-in Dolby Digital decoder.

---

## [DTS] (DVD VIDEO only)

Selects whether or not to output DTS signals when using the DIGITAL OUT (OPTICAL or COAXIAL) jack.

---

[ Off ] Select this when the recorder is connected to an audio component without a built-in DTS decoder.

---

[ On ] Select this when the recorder is connected to an audio component with a built-in DTS decoder.

---

## [MPEG] (DVD VIDEO only)

Selects the type of MPEG audio signal when using the DIGITAL OUT (OPTICAL or COAXIAL) jack.

---

[ PCM ] Select this when the recorder is connected to an audio component without a built-in MPEG decoder. If you play MPEG audio sound tracks, the recorder outputs stereo signals via the DIGITAL OUT (OPTICAL or COAXIAL) jack.

---

[ Bitstream ] Select this when the recorder is connected to an audio component with a built-in MPEG decoder.

---

## [Sampling Freq.] (DVD VIDEO only)

Selects the sampling frequency of the audio signal.

---

[ 48kHz ] The audio signals of DVD VIDEOS are always converted to 48 kHz/16 bit.

---

[ 96kHz ] All types of signals, including 96 kHz/24 bit, are output in their original format.

---

### [Audio DRC] (Dynamic Range Control) (Dolby Digital DVDs only)

Makes the sound clear when the volume is turned down when playing a DVD that conforms to [Audio DRC]. This affects the output from the following jacks:

- LINE 2 OUT (AUDIO L/R) jacks
- LINE 1-TV jack
- LINE 3/DECODER jack
- DIGITAL OUT (OPTICAL or COAXIAL) jack only when [Dolby Digital] is set to [D-PCM] (page 75).

[ Off ]	Normally select this.
[ On ]	Makes low sounds clear even if you turn the volume down.

### [Vocal] (Karaoke DVD only)

Mixes karaoke channels into normal stereo. This function is effective for multi-channel karaoke DVDs only.

[ Off ]	Does not mix karaoke channels into normal stereo. You can turn off the guide vocal on a multi-channel DVD.
[ On ]	Normally select this.

## Parental Control Settings

Playback of some DVD VIDEOS can be limited according to a predetermined level, such as the age of the users. Scenes may be blocked or replaced with different scenes.

Select  [Parental Control] in the Setup Display. To use the display, see "Using the Setup Displays" (page 69).

### [Set Password]

Sets or changes the password for [Parental Control].

- 1 Select [Set Password] and press . If you have not entered a password, the display for entering a new password appears.

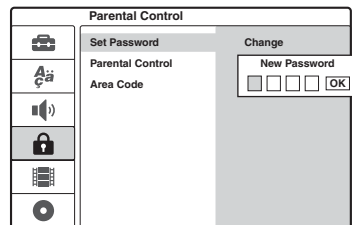

Enter a four-digit password using the number buttons and press ENTER. Enter the password again to confirm, and press ENTER while [OK] is selected.

The password is stored.

- If you make a mistake, press  repeatedly to delete numbers one by one, then re-enter it.
- 2 To change the password, press ENTER while [Change] is selected.  
[Erase]: Erases the password. Enter the registered password and press ENTER.
  - 3 Enter the registered password and press ENTER.
  - 4 Enter a new four-digit password and press ENTER.
  - 5 Enter the password again to confirm and press ENTER.

## Hint

If you forget your password, clear the password and registered a new password.  
Press SET UP to turn on the Setup Display. Enter the six-digit number 210499 using the number buttons. Select [OK] and press ENTER. The registered password is cleared.

## [Parental Control]

Selects the limitation level.

- 1 Select [Parental Control] and press →.

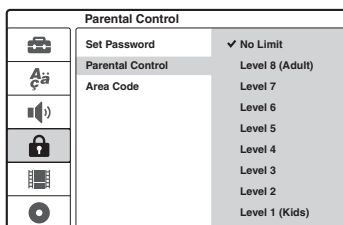

The display asks for the password.

- 2 Enter the four-digit password using the number buttons and press ENTER.
- 3 Select the level and press ENTER.  
The lower the level, the stricter the limitation.  
If you select [No Limit], the Parental Control function does not activate.

## [Area Code]

Selects a code for a geographic area as the playback limitation level. See “Area Code List” (page 93).

- 1 Select [Area Code] and press →.
- 2 Enter the four-digit password using the number buttons and press ENTER.
- 3 Press ↑/↓ to enter the first character of the area and press →.
- 4 Press ↑/↓ to enter the second character and press ENTER.

## Notes

- When you play discs which do not have the Parental Control function, playback cannot be limited on this recorder.
- Depending on the disc, you may be asked to change the Parental Control level while playing the disc. In this case, enter your password, then change the level.

# Recording Settings

The [Rec Setting] Setup allows you to adjust the recording picture quality and size.

Select [Rec Setting] in the Setup Display. To use the display, see “Using the Setup Displays” (page 69). The default settings are underlined.

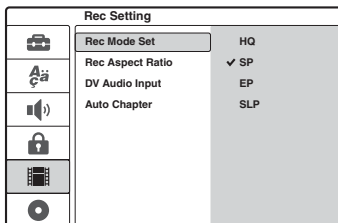

## [Rec Mode Set]

Selects one of the following recording modes: HQ (High Quality), SP (Standard Play), EP (Extended Play), SLP (Super Long Play).

## [Rec Aspect Ratio] (DVD-RW (VR mode) only)

Selects the picture size of the programme to be recorded.

When recording on discs other than DVD-RWs (VR mode), the screen size is fixed to 4:3.

[ <u>4:3</u> ]	Sets the picture size to 4:3.
[ 16:9 ]	Sets the picture size to 16:9 (wide mode).

## [DV Audio Input]

Selects the stereo track when recording from a digital video camera connected to the DV IN jack on the front panel.

[ <u>Stereo 1</u> ]	Records original sound at the time of shooting. Normally select this when dubbing a DV/Digital8 format tape.
[ Stereo 2 ]	Records only additional sound over-dubbed after shooting.

## [Auto Chapter]

Automatically divides a recording (a title) into chapters by inserting chapter markings at a specified interval. The markings are inserted while the recording is being made.

[ Off ]	No chapter mark is inserted.
---------	------------------------------

[ 5Min ]	Sets the interval to 5 minutes.
[ 10Min ]	Sets the interval to 10 minutes.
[ 15Min ]	Sets the interval to 15 minutes.

### Note

Depending on the size of the recording being made, the actual interval may vary from the interval selected in [Auto Chapter]. The selected interval should only be used as an approximation to create chapters.

## Resetting the Recorder (Factory Setup)

Select this to reset the recorder to all its default settings. The [Parental Control], [Auto Preset], [Clock], and [OSD] settings remain as stored.

- 1** Press **SET UP** to turn on the Setup Display.
- 2** Select **[Settings]** and press **→**.
- 3** Select **[Factory Setup]** and press **→**.

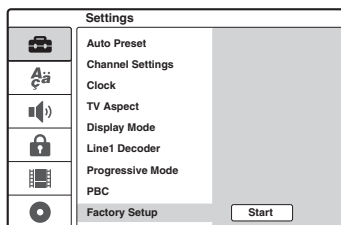

- 4** Press **ENTER** while **[Start]** is selected. The display asks for confirmation.
- 5** Select **[OK]** and press **ENTER**.

# Troubleshooting

If you experience any of the following difficulties while using the recorder, use this troubleshooting guide to help remedy the problem before requesting repairs. Should any problem persist, consult your nearest Sony dealer.

## Power

### The power does not turn on.

- ➔ Check that the mains lead is connected securely.

## Picture

### There is no picture.

- ➔ Re-connect all connecting cords securely.
- ➔ The connecting cords are damaged.
- ➔ Check the connection to your TV (page 13).
- ➔ Switch the input selector on your TV (such as to “VCR”) so that the signal from the recorder appears on the TV screen.
- ➔ If you connect the recorder to your TV via the LINE 1-TV jack, set the VIDEO OUT SELECT switch on the rear panel to “RGB” (page 14).
- ➔ If you connect the recorder to your TV via only the COMPONENT VIDEO OUT jacks, set the VIDEO OUT SELECT switch on the rear panel to “COMPONENT” (page 14).
- ➔ When [Progressive Mode] is set to [On] (page 73), signals are only sent to the COMPONENT VIDEO OUT jacks.
- ➔ This recorder cannot record NTSC signals.

### Picture noise appears.

- ➔ If the picture output signal from your recorder passes through your VCR to get to your TV, or if you are connected to a combination TV/VIDEO player, the copy-protection signal applied to some DVD programmes could affect picture quality. If you still experience this problem even when you connect your recorder directly to your TV, try connecting your recorder to your TV's S VIDEO input.

- ➔ You have set the recorder to progressive format (the PROGRESSIVE indicator lights up) even though your TV cannot accept the progressive signals. In this case, remove the disc and close the disc tray. Then press and hold ■ (stop) on the recorder for five seconds.
- ➔ Even if your TV is compatible with progressive format (625p) signals, the image may be affected when you set the recorder to progressive format. In this case, remove the disc and close the disc tray. Then press and hold ■ (stop) on the recorder for five seconds.
- ➔ You are playing a disc recorded in a colour system that is different from your TV.

### TV programme reception does not fill the screen.

- ➔ Set the channel manually in [Channel Settings] in [Settings] Setup (page 70).
- ➔ Select the correct source using the INPUT SELECT button, or select a channel of any TV programme using the PROG +/- buttons.

### TV programme pictures are distorted.

- ➔ Reorient the TV aerial.
- ➔ Adjust the picture (see the TV's instruction manual).
- ➔ Place the recorder and TV farther apart.
- ➔ Place the TV and any bunched aerial cables farther apart.
- ➔ The RF cable is connected to the AERIAL OUT jack on the recorder. Connect the cable to the AERIAL IN jack.

### TV channels cannot be changed.

- ➔ The channel is disabled (page 70).
- ➔ A timer recording started, which changed the channels.

---

**The picture from equipment connected to the recorder's input jack does not appear on the screen.**

- ➔ If the equipment is connected to the LINE 1-TV jack, select "LINE 1" in the front panel display by pressing INPUT SELECT.
- If the equipment is connected to the LINE 2 IN jacks, select "LINE 2" in the front panel display by pressing INPUT SELECT.
- If the equipment is connected to the LINE 4 IN jacks, select "LINE 4" in the front panel display by pressing INPUT SELECT.
- If the equipment is connected to the LINE 3/DECODER jack, select "LINE 3" in the front panel display by pressing INPUT SELECT.
- If the equipment is connected to the DV IN jack, (this is usually for a digital video camera connection), select "DV" in the front panel display by pressing INPUT SELECT.

---

**The playback picture or TV programme from the equipment connected through the recorder is distorted.**

- ➔ If the playback picture output from a DVD player, VCR, or tuner goes through your recorder before reaching your TV, the copy-protection signal applied to some programmes could affect picture quality. Disconnect the playback equipment in question and connect it directly to your TV.

---

**The picture does not fill the screen.**

- ➔ Set [TV Aspect] in [Settings] Setup in accordance with the aspect ratio of your TV (page 73).

---

**The picture does not fill the screen, even though the aspect ratio is set in [TV Aspect] in [Settings] Setup.**

- ➔ The aspect ratio of the disc is fixed on your DVD.

---

**The picture is black and white.**

- ➔ If you are using a SCART cord, be sure to use one that is fully wired (21 pins).

---

**Sound****There is no sound.**

- ➔ Re-connect all connections securely.
- ➔ The connecting cord is damaged.
- ➔ The input source setting on the amplifier or the connection to the amplifier is incorrect.

- ➔ The recorder is in reverse play, fast forward, slow motion, or pause mode.
- ➔ If the audio signal does not come through the DIGITAL OUT (OPTICAL or COAXIAL) jacks, check the [Audio] Setup settings (page 75).

---

**Sound is noisy.**

- ➔ When playing a CD with DTS sound tracks, noise will come from the LINE 2 OUT (AUDIO L/R) jacks, LINE 1-TV jack, or LINE 3/DECODER jack (page 51).

---

**The sound volume is low.**

- ➔ The sound volume is low on some DVDs. The sound volume may improve if you set [Audio DRC] in [Audio] Setup to [On] (page 76).

---

**An alternate audio track cannot be recorded or played.**

- ➔ If an audio channel other than "Main+Sub" is selected, you cannot record both main and sub sounds. Check the selected audio channel before you start recording.
- ➔ If you have connected an AV amplifier to the DIGITAL OUT (OPTICAL or COAXIAL) jack and want to change the audio track during playback, set [Dolby Digital] in [Audio] Setup to [D-PCM] (page 75).

---

**Playback****The disc does not play.**

- ➔ The disc is upside down. Insert the disc with the playback side facing down.
- ➔ The disc is not correctly inserted.
- ➔ Moisture has condensed inside the recorder. Remove the disc and leave the recorder turned on for about half an hour until the moisture evaporates.
- ➔ If the disc was recorded on another recorder, the recorder cannot play the disc if it was not finalized (page 35).

---

**The disc does not start playback from the beginning.**

- ➔ Resume play was activated (page 48).
- ➔ You have inserted a disc whose Title menu or DVD menu automatically appears on the TV screen when it is first inserted. Use the menu to start playback.



---

**The recorder starts playing the disc automatically.**

- ➔ The DVD VIDEO features an auto playback function.

---

**Playback stops automatically.**

- ➔ If the disc has an auto pause signal, the recorder stops playback at the auto pause signal.

---

**Some functions such as Stop, Search, or Slow-motion Play cannot be performed.**

- ➔ Depending on the disc, you may not be able to do some of the operations above. See the instructions supplied with the disc.

---

**The language for the sound track cannot be changed.**

- ➔ Multilingual tracks are not recorded on the disc being played.
- ➔ The DVD VIDEO prohibits the changing of the language for the sound track.
- ➔ Try changing the language using the DVD VIDEO's menu.

---

**The subtitle language cannot be changed or turned off.**

- ➔ Multilingual subtitles are not recorded on the DVD VIDEO.
- ➔ The DVD VIDEO prohibits changing of the subtitles.
- ➔ Try changing the subtitle using the DVD VIDEO's menu.
- ➔ The subtitles cannot be changed for the titles recorded on this recorder.

---

**The angles cannot be changed.**

- ➔ Multi-angles are not recorded on the DVD VIDEO being played.
- ➔ You are trying to change the angles when “” does not appear in the front panel display (page 49).
- ➔ The DVD VIDEO prohibits changing angles.
- ➔ Try changing the angle using the DVD VIDEO's menu.
- ➔ The angles cannot be changed for the titles recorded on this recorder.

---

**The MP3 audio tracks or JPEG image files do not play.**

- ➔ The MP3 audio tracks or JPEG image files are not recorded in a format that the recorder can play (page 10).

---

**Recording/Timer recording/Editing**

---

**The programme position cannot be changed from the channel you are recording.**

- ➔ Set the TV's input source to “TV.”

---

**Recording does not start immediately after you press ● REC.**

- ➔ Operate the recorder only after “LOADING,” “INITIALIZE,” or “WRITE DISC” disappears from the front panel display.

---

**Nothing was recorded even though you set the timer setting correctly.**

- ➔ The recorder was turned on when the timer recording start time came. Set the recorder to standby mode before timer recording starts.
- ➔ There was a power failure during recording.
- ➔ The recorder's internal clock stopped due to a power failure. Reset the clock (page 72).
- ➔ The channel was disabled after the timer recording was set. See [Channel Settings] on page 70.
- ➔ Disconnect the mains lead from the mains, and connect it again.
- ➔ The programme contains copy protection signals that restrict copying.
- ➔ Other timer setting overlapped the timer setting (page 42).
- ➔ There is no recordable disc inserted in the recorder.
- ➔ There is not enough disc space for the recording.
- ➔ The disc is protected (DVD+RW, DVD-RW, DVD+R) (page 34).
- ➔ The recorder was in the process of DV Dubbing (page 66).

---

**Recording does not stop immediately after you press ■.**

- ➔ It will take a few seconds for the recorder to input disc data before recording can stop.

---

**Timer recording is not complete or did not start from the beginning.**

- ➔ There was a power failure before or during recording. Reset the clock (page 72).

- ➔ Other timer setting overlapped the timer setting (page 42).
- ➔ There is not enough disc space for the recording.
- ➔ The PDC/VPS function is working (page 39).

---

### Contents previously recorded were erased.

- ➔ Data that has been recorded on a DVD with a PC will be erased from the disc when the disc is inserted.

---

### The PDC/VPS function does not operate.

- ➔ Check that the clock and date are set correctly.
- ➔ Check that the PDC/VPS time you set is the correct one (there might be a mistake in the TV programme guide). If the broadcast you wanted to record did not send the good PDC/VPS information, the recorder will not start recording.
- ➔ If the reception is poor, the PDC/VPS signal might be altered and the recorder might not start recording.
- ➔ [PDC/VPS] is set to [Off] (page 39).

---

## Display

### The clock has stopped.

- ➔ Set the clock again (page 72).
- ➔ The clock stopped due to a power failure. Reset the clock (page 72).

---

### The TIMER REC indicator is flashing.

- ➔ The disc does not have enough space.
- ➔ Insert a recordable disc inside the recorder.

---

### The recording mode indication is incorrect.

- ➔ When the recording or dubbing is less than three minutes, the recording mode indication may be displayed incorrectly. The actual recording itself is correctly made in the selected recording mode.

---

## Remote control

### The remote does not function.

- ➔ Batteries are weak.
- ➔ The remote is too far from the recorder.
- ➔ The remote's manufacturer code returned to the default setting when you replaced the batteries. Reset the code (page 19).
- ➔ Turn on the recorder.
- ➔ The remote is not pointed at the remote sensor on the recorder.
- ➔ Different command modes are set for the recorder and remote. Set the same command mode (page 20).

- ➔ Set the TV/DVD switch to DVD (page 19).

---

### Other Sony equipment responds to the remote.

- ➔ The same command mode is set for both the equipment and recorder. Set a different command mode for the recorder (page 20).

---

## Others

### The recorder does not operate properly.

- ➔ Restart the recorder. Press down I/⏻ on the recorder for more than ten seconds to turn off the recorder. If a disc is still in the recorder, press ▲ (open/close) and remove the disc.
- ➔ When static electricity, etc., causes the recorder to operate abnormally, turn off the recorder and wait until the clock appears in the front panel display. Then, unplug the recorder and after leaving it off for a while, plug it in again.

---

### The disc tray does not open after you press ▲ (open/close).

- ➔ It may take a few seconds for the disc tray to open after you have recorded or edited a disc. This is because the recorder is adding disc data to the disc.

---

### Mechanical sound is heard when the recorder is off.

- ➔ While the recorder is adjusting the clock for the Auto Clock Set function or scanning the channels for the PDC/VPS function, operational noises (such as the internal fan) may be heard, even when the power is off. This is not a malfunction.

## Notes About This Recorder

### On operation

- If the recorder is brought directly from a cold to a warm location, or is placed in a very damp room, moisture may condense on the lenses inside the recorder. Should this occur, the recorder may not operate properly. In this case, remove the disc and leave the recorder turned on for about half an hour until the moisture evaporates.
- When you move the recorder, take out any discs. If you do not, the disc may be damaged.

### On adjusting volume

Do not turn up the volume while listening to a section with very low level inputs or no audio signals. If you do, the speakers may be damaged when a peak level section is played.

### On cleaning

Clean the cabinet, panel, and controls with a soft cloth slightly moistened with a mild detergent solution. Do not use any type of abrasive pad, scouring powder or solvent such as alcohol or benzine.

### On cleaning discs

Do not use a commercially available cleaning disc. It may cause a malfunction.

### Notes about the discs

- To keep the disc clean, handle the disc by its edge. Do not touch the surface. Dust, fingerprints, or scratches on the disc may cause it to malfunction.



- After playing, store the disc in its case.
- Clean the disc with a cleaning cloth. Wipe the disc from the centre out.

- Do not use solvents such as benzine, thinner, commercially available cleaners, or anti-static spray intended for vinyl LPs.
- Do not use the following discs.
  - A disc that has a non-standard shape (e.g., card, heart).
  - A disc with a label or sticker on it.
  - A disc that has cellophane tape or sticker adhesive on it.

- Do not expose the disc to direct sunlight or heat sources such as hot air ducts, or leave it in a car parked in direct sunlight as the temperature may rise considerably inside the car.

---

# Specifications

## System

**Laser:** Semiconductor laser

### Channel coverage:

PAL/SECAM (B/G, D/K, I, L)  
VHF: E2 to E12, R1 to R12, F1 to F10, Italian  
A to H, Ireland A to J, South Africa 4 to 13/  
UHF: E21 to E69, R21 to R69, B21 to B69,  
F21 to F69/CATV: S01 to S05, S1 to S20,  
France B to Q/HYPER: S21 to S41

The above channel coverage merely ensures the channel reception within these ranges. It does not guarantee the ability to receive signals in all circumstances.

**Video reception:** Frequency synthesizer system

**Audio reception:** Split carrier system

**Aerial out:** 75-ohm asymmetrical aerial socket

**Timer:** Clock: Quartz locked/Timer indication:  
24-hour cycle (digital)

**Video recording format:** MPEG Video

**Audio recording format:** Dolby Digital/2 ch

## Inputs and outputs

### LINE 2 OUT

(**AUDIO**): Phono jack/2 V<sub>rms</sub>/600 ohms

(**VIDEO**): Phono jack/1.0 V<sub>p-p</sub>

(**S VIDEO**): 4-pin mini DIN/Y:1.0 V<sub>p-p</sub>, C: 0.3  
V<sub>p-p</sub> (PAL)

### LINE 2 IN/LINE 4 IN

(**AUDIO**): Phono jack/2 V<sub>rms</sub>/more than 47  
kilohms

(**VIDEO**): Phono jack/1.0 V<sub>p-p</sub>

(**S VIDEO**): 4-pin mini DIN/Y:1.0 V<sub>p-p</sub>, C: 0.3  
V<sub>p-p</sub> (PAL)

### LINE 1 -TV: 21-pin

CVBS IN/OUT

RGB OUT (upstream)

### LINE 3/DECODER: 21-pin

CVBS IN/OUT

Decoder

**DV IN:** 4-pin/i.LINK S100

**DIGITAL OUT (OPTICAL):** Optical output  
jack/-18 dBm (wave length: 660 nm)

**DIGITAL OUT (COAXIAL):** Phono jack/0.5  
V<sub>p-p</sub>/75 ohms

## COMPONENT VIDEO OUT

(**Y, P<sub>B</sub>/C<sub>B</sub>, P<sub>R</sub>/C<sub>R</sub>**):

Phono jack/Y: 1.0 V<sub>p-p</sub>, P<sub>B</sub>/C<sub>B</sub>: 0.7 V<sub>p-p</sub>,

P<sub>R</sub>/C<sub>R</sub>: 0.7 V<sub>p-p</sub>

## General

**Power requirements:** 220-240 V AC, 50/60 Hz

**Power consumption:** 30W

**Dimensions (approx.):** 430 × 75 × 293 mm  
(width/height/depth) incl. projecting parts

**Mass (approx.):** 4.0 kg

**Operating temperature:** 5 °C to 35 °C

**Operating humidity:** 25 % to 80 %

### Supplied accessories:

Audio cord (1)

Video cord (1)

Aerial cable (1)

Remote commander (remote) (1)

R6 (size AA) batteries (2)

Specifications and design are subject to change without notice.

## Compatible colour systems

This recorder is designed to record and play using the PAL colour system.

The signals of the SECAM colour system can be received or recorded but played back in the PAL colour system only. Recording of video sources based on other colour systems cannot be guaranteed.

---

## About i.LINK

The DV IN jack on this recorder is an i.LINK-compliant DV IN jack. This section describes the i.LINK standard and its features.

### What is i.LINK?

i.LINK is a digital serial interface for handling digital video, digital audio and other data in two directions between equipment having the i.LINK jack, and for controlling other equipment.

i.LINK-compatible pieces of equipment can be connected by a single i.LINK cable. Possible applications are operations and data transactions with various digital AV equipment. When two or more i.LINK-compatible equipment are connected to this recorder in a daisy chain, operations and data transactions are possible with not only the equipment that this recorder is connected to but also with other devices via the directly connected equipment.

Note, however, that the method of operation sometimes varies according to the characteristics and specifications of the equipment to be connected, and that operations and data transactions are sometimes not possible on some connected equipment.

### Note

Normally, only one piece of equipment can be connected to this recorder by the i.LINK cable (DV connecting cable). When connecting this recorder to i.LINK-compatible equipment having two or more i.LINK jacks (DV jacks), see the instruction manual of the equipment to be connected.

---

## About the name “i.LINK”

i.LINK is a more familiar term for IEEE 1394 data transport bus proposed by SONY, and is a trademark approved by many corporations. IEEE 1394 is an international standard standardized by the Institute of Electrical and Electronics Engineers.

---

## i.LINK baud rate

i.LINK’s maximum baud rate varies according to the equipment. Three maximum baud rates are defined:

- S100 (approx. 100 Mbps\*)
- S200 (approx. 200 Mbps)
- S400 (approx. 400 Mbps)

The baud rate is listed under “Specifications” in the instruction manual of each equipment. It is also indicated near the i.LINK jack on some equipment.

The maximum baud rate of equipment on which it is not indicated such as this unit is “S100.”

When units are connected to equipment having a different maximum baud rate, the baud rate sometimes differs from the indicated baud rate.

\*What is Mbps?

Mbps stands for megabits per second, or the amount of data that can be sent or received in one second. For example, a baud rate of 100 Mbps means that 100 megabits of data can be sent in one second.

---

## i.LINK functions on this recorder

For details on how to dub when this recorder is connected to other video equipment having DV jacks, see page 66.

The DV jack on this recorder can only input DVC-SD signals. It cannot output signals. The DV jack will not accept MICRO MV signals from equipment such as a MICRO MV digital video camera with an i.LINK jack.

For further precautions, see the notes on page 66. For details on precautions when connecting this recorder, also see the instruction manuals for the equipment to be connected.

---

## Required i.LINK cable

Use the Sony i.LINK 4-pin-to-4-pin cable (during DV dubbing).

i.LINK and  are trademarks.

# Guide to Parts and Controls

For more information, see the pages in parentheses.

## Front panel

Buttons on the recorder have the same function as the buttons on the remote if they have the same or similar names.

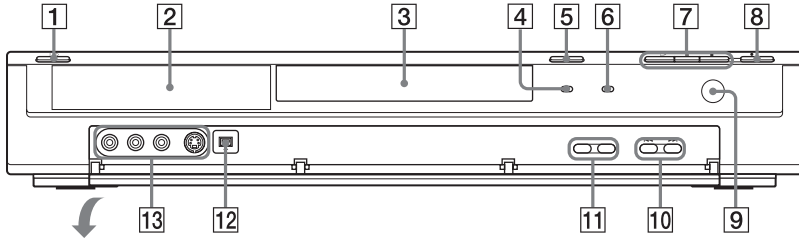

**1** I/⏻ (on/standby) button (21, 27, 38, 40)

**2** Front panel display (31, 88)

**3** Disc tray (27)

**4** TIMER REC indicator (38, 40)

**5** ⏏ (open/close) button (27, 49, 54)

**6** PROGRESSIVE indicator (15)

**7** ▷ (play) button (47, 53)

▢ (pause) button (43, 49, 54, 57)

■ (stop) button (20, 28, 29, 73)

**8** ● REC button (28, 43, 45, 67)

**9** 📡 (remote sensor) (18)

**10** ◀▶ (previous/next) buttons (20, 49, 54)

**11** PROGRAM +/- buttons (28, 43)

**12** i DV IN jack (66)

**13** LINE 2 IN (VIDEO, AUDIO L/R, S VIDEO) jacks (24)

## Remote

Buttons on the remote have the same function as the buttons on the recorder if they have the same or similar names. Buttons with an orange dot next to them can be used with your TV when the TV/DVD switch is set to TV.

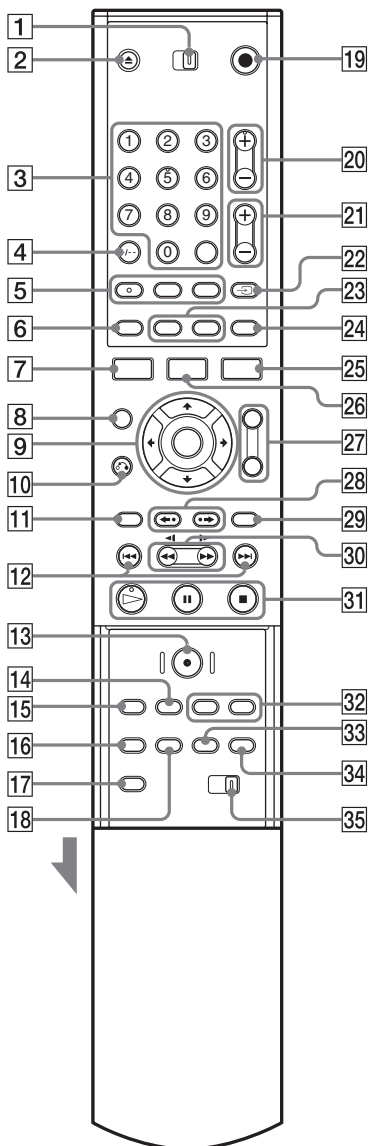

- 1 TV/DVD switch (19, 20, 27)
- 2 ▲ (open/close) button (27, 49, 54)
- 3 Number buttons\* (33, 40, 52)  
SET button (52)  
The number 5 button has a tactile dot.
- 4 CLEAR/-/- (ten digit) button (40, 42, 52)
- 5 ○○○ (audio) button\* (49)  
The button has a tactile dot.  
⋮ (subtitle) button (49)  
⌂ (angle) button (49)
- 6 TIME button (31)
- 7 DISPLAY button (31, 44, 52)
- 8 □ (Picture-in-Picture) button (51)
- 9 ←/↑/↓/→/ENTER button (21, 29, 32)
- 10 ↶ RETURN button (29, 38, 42, 53, 57)
- 11 TOP MENU button (47, 53, 57)
- 12 ◀◀ (previous)/▶▶ (next) buttons (49, 54, 57)
- 13 ● REC button (28, 43, 45, 67)
- 14 INPUT SELECT button (45, 67)
- 15 REC MODE button (28, 37, 45, 67)
- 16 REPEAT button (51, 54)
- 17 SET UP button (21, 27, 69)
- 18 A-B button (51, 54)
- 19 ⏻/⏻ (on/standby) button (19, 21, 27, 38, 40)
- 20 PROG (programme) +/- buttons\* (28, 43)  
The + button has a tactile dot.
- 21 ▽ (volume) +/- buttons (19)
- 22 ↻ (TV/video), TV/DVD button (19, 44)
- 23 SUR (surround) button (49, 54)  
ZOOM button (50)
- 24 ⌂ (wide mode) button (19)
- 25 TIMER button (38, 40, 42)
- 26 TITLE LIST button (29, 47, 60)
- 27 BOOKMARK button (52)  
SEARCH MODE button (52)
- 28 ◀• (instant replay)/•▶ (instant advance) buttons (49)

- 29** MENU button (47, 53)
- 30** ◀◀◀/▶▶▶ (search) buttons (49, 54)
- 31** ▷ (play) button\* (47, 53)  
The button has a tactile dot.
- ⏸ (pause) button (43, 49, 54, 57)
- (stop) button (28, 29)
- 32** CHAPTER MARK button (64)  
PICTURE MARK button (30)
- 33** RANDOM button (51, 54)
- 34** PROGRAM button (55)
- 35** COMMAND MODE switch (DVD 1, 2, 3) (20)

\* Use the tactile dot as a reference when operating the recorder.

## Front panel display

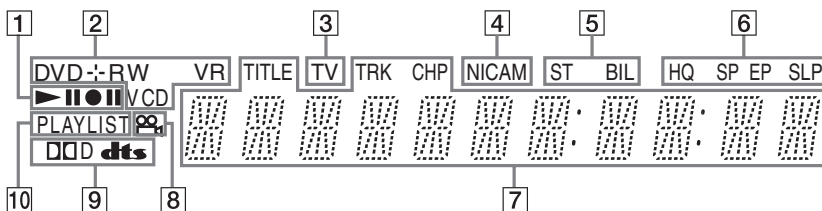

- 1** Playing/recording status (31, 44)
- 2** Disc type\*/recording format (8)
- 3** TV indicator (19)
- 4** NICAM indicator (37)
- 5** ST (stereo)/BIL (bilingual) indicators (37)
- 6** Recording mode indicators (28, 37, 45, 67)
- 7** Displays the following (31, 44, 52):
- Playing time/remaining time
  - Current title/chapter/track number
  - Recording time/remaining time
  - Clock
  - Programme position
- 8** ∞ (angle) indicator (49)
- 9** Audio signal indicators (31, 49, 53)
- 10** PLAYLIST indicator (29, 59)

\*Displays DATA CDs as "CD."



## Rear panel

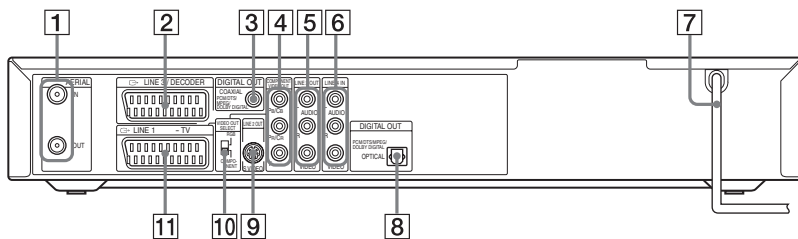

- 1** AERIAL IN/OUT jacks (13)
- 2** LINE 3/DECODER jack (23, 25, 26)
- 3** DIGITAL OUT (COAXIAL) jack (16)
- 4** COMPONENT VIDEO OUT (P<sub>B</sub>/C<sub>B</sub>, P<sub>R</sub>/C<sub>R</sub>, Y) jacks (14)
- 5** LINE 2 OUT (AUDIO L/R, VIDEO) jacks (14, 16)
- 6** LINE 4 IN (AUDIO L/R, VIDEO) jacks (24)
- 7** Mains lead (18)
- 8** DIGITAL OUT (OPTICAL) jack (16)
- 9** LINE 2 OUT (S VIDEO) jack (14)
- 10** VIDEO OUT SELECT switch (14)
- 11** LINE 1 – TV jack (14)

---

# Glossary

---

## Album (page 53)

A unit in which to store MP3 audio tracks on a DATA CD. (Album is an exclusive definition for this recorder.)

---

## Chapter (page 52)

Sections of a picture or a music feature that are smaller than titles. A title is composed of several chapters. Depending on the disc, no chapters may be recorded.

---

## Copy protection signals (page 38)

Copy restriction set by copyright owners, etc. These signals are included in some software or TV programmes and restrict recording on this recorder.

---

## Dolby Digital (page 75)

Digital audio compression technology developed by Dolby Laboratories. This technology conforms to multi-channel surround sound. The rear channel is stereo and there is a discrete subwoofer channel in this format. Dolby Digital provides the same discrete channels of high quality digital audio found in “Dolby Digital” theater surround sound systems.

Good channel separation is realized because all of the channel data is recorded discretely, and little deterioration occurs because all channel data processing is digital.

---

## DTS (page 75)

Digital audio compression technology by Digital Theater Systems, Inc. This technology conforms to multi-channel surround sound. The rear channel is stereo and there is a discrete subwoofer channel in this format. DTS provides the same discrete channels of high quality digital audio.

Good channel separation is realized because all of the channel data is recorded discretely, and little deterioration occurs because all channel data processing is digital.

---

---

## DVD+R (page 8)

A DVD+R (read “plus R”) is a recordable disc that is the same size as a DVD VIDEO. Contents can be recorded only once to a DVD+R, and will have the same format as a DVD VIDEO.

---

## DVD-R (page 8)

A DVD-R is a recordable disc that is the same size as a DVD VIDEO. Contents can be recorded only once to a DVD-R, and will have the same format as a DVD VIDEO.

---

## DVD+RW (page 8)

A DVD+RW (read “plus RW”) is a recordable and rewritable disc. DVD+RWs use a recording format that is comparable to the DVD VIDEO format.

---

## DVD-RW (page 8)

A DVD-RW is a recordable and rewritable disc that is the same size as a DVD VIDEO. The DVD-RW has two different modes: VR mode and Video mode. DVDs created in Video mode have the same format as a DVD VIDEO, while discs created in VR (Video Recording) mode allow the contents to be programmed or edited.

---

## DVD VIDEO (page 10)

A disc that contains up to eight hours of moving pictures on a disc the same diameter as a CD. The data capacity of a single-layer and single-sided DVD is 4.7 GB (Giga Byte), which is 7 times that of a CD. The data capacity of a double-layer and single-sided DVD is 8.5 GB, a single-layer and double-sided DVD is 9.4 GB, and double-layer and double-sided DVD is 17 GB.

The picture data uses the MPEG 2 format, which is a worldwide standard of digital compression technology. The picture data is compressed to about 1/40 (average) of its original size. The DVD also uses a variable rate coding technology that changes the data to be allocated according to the status of the picture. Audio information is recorded in a multi-channel format, such as Dolby Digital, allowing you to enjoy a more real audio presence.

Furthermore, various advanced functions such as the multi-angle, multilingual, and Parental Control functions are provided on the DVD.

---

---

**File (page 57)**

A JPEG image recorded on a DATA CD. (File is an exclusive definition for this recorder.) A single file consist of a single image.

---

**Folder (page 57)**

A unit in which to store JPEG image files on a DATA CD. (Folder is an exclusive definition for this recorder.)

---

**Interlace format (page 73)**

Interlace format shows every other line of an image as a single “field” and is the standard method for displaying images on television. The even number field shows the even numbered lines of an image, and the odd numbered field shows the odd numbered lines of an image.

---

**MPEG Audio (page 75)**

International standard coding system used to compress audio digital signals authorized by ISO/IEC. MPEG 2, used on DVDs, conforms to up to 7.1-channel surround.

---

**Original (page 59)**

Titles actually recorded on a DVD-RW (VR mode). Erasing original titles frees up disc space.

---

**Playlist (page 59)**

Playback information created from the actual recordings on a DVD-RW (VR mode). A Playlist leaves the original titles as they are, and contains only the information needed to control playback. A Playlist title takes up very little disc space.

---

**Progressive format (page 73)**

Compared to the Interlace format that alternately shows every other line of an image (field) to create one frame, the Progressive format shows the entire image at once as a single frame. This means that while the Interlace format can show 25-30 frames/50-60 fields in one second, the Progressive format can show 50/60 frames in one second. The overall picture quality increases and still images, text, and horizontal lines appear sharper.

---

**Title (page 52)**

The longest section of a picture or music feature on a DVD, movie, etc., in video software, or the entire album in audio software.

---

---

**Track (page 52)**

Sections of a picture or a music feature on a VIDEO CD, CD, or DATA CD (the length of a song). (Track is an exclusive definition for this recorder.)

# Language Code List

For details, see page 74.

The language spellings conform to the ISO 639: 1988 (E/F) standard.

Language	Code	Language	Code	Language	Code	Language	Code
Abkhazian	6566	Galician	7176	Marathi	7782	Tatar	8484
Afar	6565	Georgian	7565	Moldavian	7779	Telugu	8469
Afrikaans	6570	German	6869	Mongolian	7778	Thai	8472
Albanian	8381	Greek	6976	Nauru	7865	Tibetan	6679
Amharic	6577	Greenlandic	7576	Nepali	7869	Tigrinya	8473
Arabic	6582	Guarani	7178	Norwegian	7879	Tonga	8479
Armenian	7289	Gujarati	7185	Oriya	7982	Turkish	8482
Assamese	6583	Hausa	7265	Punjabi	8065	Turkmen	8475
Aymara	6588	Hebrew	7387	Pashto; Pushto	8083	Twi	8487
Azerbaijani	6590	Hindi	7273	Persian	7065	Ukrainian	8575
Bashkir	6665	Hungarian	7285	Polish	8076	Urdu	8582
Basque	6985	Icelandic	7383	Portuguese	8084	Uzbek	8590
Bengali; Bangla	6678	Indonesian	7378	Quechua	8185	Vietnamese	8673
Bhutani	6890	Interlingua	7365	Rhaeto-Romance		Volapük	8679
Bihari	6672	Irish	7165	Romanian	8277	Welsh	6789
Breton	6682	Italian	7384	Russian	8285	Wolof	8779
Bulgarian	6671	Japanese	7465	Samoan	8377	Xhosa	8872
Burmese	7789	Javanese	7487	Sanskrit	8365	Yiddish	7473
Byelorussian	6669	Kannada	7578	Scots Gaelic	7168	Yoruba	8979
Cambodian	7577	Kashmiri	7583	Serbian	8382	Zulu	9085
Catalan	6765	Kazakh	7575	Serbo-Croatian	8372		
Chinese	9072	Kirghiz	7589	Shona	8378		
Corsican	6779	Korean	7579	Sindhi	8368		
Croatian	7282	Kurdish	7585	Singhalese	8373		
Czech	6783	Laothian	7679	Slovak	8375		
Danish	6865	Latin	7665	Slovenian	8376		
Dutch	7876	Latvian; Lettish	7686	Somali	8379		
English	6978	Lingala	7678	Spanish	6983		
Esperanto	6979	Lithuanian	7684	Sundanese	8385		
Estonian	6984	Macedonian	7775	Swahili	8387		
Faroese	7079	Malagasy	7771	Swedish	8386		
Fiji	7074	Malay	7783	Tagalog	8476		
Finnish	7073	Malayalam	7776	Tajik	8471		
French	7082	Maltese	7784	Tamil	8465		
Frisian	7089	Maori	7773				

# Area Code List

For details, see page 77.

Code Area	Code Area	Code Area	Code Area
AF	Afghanistan	FI	Finland
AN	Netherlands Antilles	FJ	Fiji
AR	Argentina	FR	France
AT	Austria	GB	Great Britain
AU	Australia	GL	Greenland
BE	Belgium	GR	Greece
BO	Bolivia	HK	Hong Kong
BR	Brazil	HM	Heard and McDonald Islands
BT	Bhutan	HR	Croatia
CA	Canada	HU	Hungary
CG	Congo	ID	Indonesia
CH	Switzerland	IL	Israel
CL	Chile	IN	India
CN	China	IT	Italy
CO	Colombia	JM	Jamaica
CR	Costa Rica	JP	Japan
CZ	Czech Republic	KE	Kenya
DE	Germany	KH	Cambodia
DK	Denmark	KR	South Korea
EC	Ecuador	KW	Kuwait
EG	Egypt	LK	Sri Lanka
ES	Spain	LU	Luxembourg
ET	Ethiopia	LY	Libya
		MA	Morocco
		MC	Monaco
		MN	Mongolia
		MV	Maldives
		MX	Mexico
		MY	Malaysia
		NG	Nigeria
		NL	Netherlands
		NO	Norway
		NP	Nepal
		NZ	New Zealand
		OM	Oman
		PA	Panama
		PH	Philippines
		PK	Pakistan
		PL	Poland
		PT	Portugal
		PY	Paraguay
		RO	Romania
		RU	Russian Federation
		SA	Saudi Arabia
		SE	Sweden
		SG	Singapore
		SI	Slovenia
		SK	Slovak Republic
		SN	Senegal
		SV	El Salvador
		TH	Thailand
		TR	Turkey
		TW	Taiwan
		UA	Ukraine
		UG	Uganda
		US	United States
		UY	Uruguay
		UZ	Uzbekistan
		VN	Vietnam
		ZA	South Africa
		ZW	Zimbabwe

---

# Index

Words in brackets appear in the on-screen displays.

## Numerics

[16:9] 22, 73, 77  
[4:3] 22, 73, 77  
[48kHz] 75  
[96kHz] 75

## A

[A-B Erase] 61  
A-B Repeat 51, 55  
Aerial 13  
Album 53, 90  
Angle 50  
Area Code 77, 93  
Audio 74, 75  
Audio cord 16  
[Audio DRC] 76  
[Auto Adjust] 72  
[Auto Chapter] 45, 77  
Auto Clock Set 22, 72  
[Auto Preset] 21, 70

## B

Batteries 18  
Bilingual recordings 37  
[Bitstream] 75  
Bookmark 52

## C

Canal Plus 26  
CD 10  
Channel List 71  
[Channel Settings] 70  
Chapter 45, 64, 90  
Chapter List 30, 47, 63, 65  
Cleaning discs 83  
[Clock] 22, 72  
Colour systems 84  
[Combine] 63  
Command mode 20  
COMPONENT VIDEO OUT  
14

## Connecting

the aerial cable 13  
the audio cords 16  
the video cords 14

## Controlling TVs with the remote 19

Copy control signals 38  
Copy protection 90  
Copy-Free 38  
Copy-Never 38  
Copy-Once 38  
CPRM 8  
Creating chapters 64

## D

DATA CD 10  
[Decoder On/Off] 71  
DIGITAL OUT 16  
Digital video camera 66  
[Disc Info] 27  
[Disc Name] 34  
Disc space 59  
Disc types 8  
Display  
    Front panel display 31, 88  
    On-screen display 31  
    Setup Display 69  
[Display Mode] 73  
[Divide] 62  
Dolby Digital 17, 75, 90  
[D-PCM] 75  
DTS 75, 90  
[DV Audio Input] 67, 77  
DV Dubbing 66  
DV IN 66  
DVD VIDEO 10, 90  
DVD+R 8, 90  
DVD+RW 8, 90  
DVD-R 8, 90  
DVD-RW 8, 59, 90

## E

[Edit] 34, 61, 63  
Editing 59  
Enter characters 32  
[Erase] 61, 63, 71

## F

[Factory Setup] 78  
File 57, 91  
[Finalize] 35  
[Fine] 71  
Folder 57, 91  
[Format DVD] 27  
Front panel 86  
Front panel display 31, 88  
[Full Play] 48, 64

## H

Handling discs 83  
[Hide] 64

## I

i.LINK 85  
INPUT SELECT 45, 67  
Interlace format 91

## J

JPEG image files 57

## L

[Letter Box] 73  
LINE 1 – TV 14  
LINE 2 IN 24  
LINE 2 OUT 14, 16  
LINE 3/DECODER 23, 25, 26  
LINE 4 IN 24  
[Line1 Decoder] 73

## M

Mains lead 18  
Manual Clock Set 72  
MENU 47  
Menu 74  
    DVD's Menu 47  
    Top menu 47  
[Move] 65, 71  
MP3 audio tracks 53  
MPEG 75, 91

## N

NICAM 37, 71  
Number buttons 33, 40, 52

- O**
- On-screen display 31
    - Setup Display 69
    - Sub-menu 29
  - Original 29, 59, 91
  - OSD language 21, 74
- P**
- [Pan Scan] 73
  - Parental Control 48, 76, 77
  - PAY-TV 26
  - PBC (Playback Control) 47, 74
  - [PCM] 75
  - PDC 39
  - Picture-in-Picture 51
  - Playable discs 10
  - Playback 47, 49, 53
    - A-B Repeat 51, 55
    - fast forward 49, 54
    - fast reverse 49, 54
    - instant advance 50
    - instant replay 50
    - Random Play 51, 55
    - Repeat Play 51, 55
    - Resume Play 48
    - Slow-motion play 50
  - Playing time 31
  - Playlist 29, 59, 64, 91
  - Programme Play 55
  - Progressive mode 15, 73, 91
  - [Protect] 34, 62
- Q**
- Quick guide to disc types 8
  - Quick Timer 44
- R**
- Random Play 51, 55
  - Rear panel 89
  - REC 28, 43
  - [Rec Aspect Ratio] 77
  - Rec Mode Adjust 40
  - [Rec Mode Set] 77
  - [Rec Setting] 67, 77
  - Recordable discs 8
  - Recording 28, 37, 43, 45, 77
    - Overwriting a recorded title 45
    - Recording format 8
    - Recording mode 37, 77
    - Recording time 37
    - while watching another programme 44
  - Region code 11
  - Remaining time 31
  - Remote 18, 87
  - Repeat Play 51, 55
  - Resetting the recorder 78
  - Resume Play 48
- S**
- S VIDEO 14, 15
  - [Sampling Freq.] 75
  - Searching
    - fast forward 49, 54
    - fast reverse 49, 54
    - locating the beginning of the title/chapter/track 49, 54
    - Search mode 52
  - SET 52
  - [Set Password] 76
  - Setup Display 69
  - [Show] 64
  - ShowView 40
  - Slide show 57
  - [Station Name] 71
  - [Stereo 1] 77
  - [Stereo 2] 77
  - Sub-menu 29
  - Subtitle 50, 74
  - Super VIDEO CD 10
  - [SUR ON] 50, 54
  - Surround 17, 50, 51, 54
- T**
- Thumbnail picture 30
  - TIME 31
  - TIMER 38, 40
  - Timer List 42
  - Timer recording
    - check/change/cancel 42
    - manual setting 38
    - Rec Mode Adjust 40
    - ShowView 40
    - Timer List 42
  - Title 29, 47, 91
  - TITLE LIST 29, 47
  - Title List 29, 47, 60
  - [Title Name] 33, 61
  - TOP MENU 47
  - Track 53, 91
  - Troubleshooting 79
  - [TV Aspect] 22, 73
  - TV/DVD 44
  - TV/DVD switch 19, 27
- U**
- [Unfinalize] 35
  - Usable discs 8, 10
- V**
- VIDEO CD 10, 47
  - Video cord 14
  - Video input 15
  - Video mode 8
  - VIDEO OUT SELECT switch 15
  - [Vocal] 76
  - VPS 39
  - VR mode 8
- Z**
- Zoom 50
  - ZWEITON 37



Printed using VOC (Volatile Organic  
Compound)-free vegetable oil based  
ink.